

CONTENTS

01 INTRODUCTION	3
SYMBOLS	3
02 BH WARRANTY	4
LIFETIME FRAME WARRANTY.....	4
EXTENDED WARRANTY OF UP TO 5 YEARS ON BH MOTORS.....	5
EXTENDED WARRANTY FOR BH BATTERIES.....	5
REGISTERING EXTENDED WARRANTIES	6
WARRANTY OF PARTS OF THE ELECTRICAL ASSISTANCE SYSTEM.....	6
SUBMITTING A WARRANTY CLAIM.....	6
CONDITIONS THAT MAY VOID THE WARRANTY OF ELECTRICAL COMPONENTS.....	6
03 MAINTENANCE	7
INSPECT THE BICYCLE BEFORE USE	7
KEEP THE BICYCLE CLEAN.....	7
KEEP THE TRANSMISSION LUBRICATED AT ALL TIMES	7
PART MAINTENANCE	7
SPARE PARTS	8
AFTER A FALL, BLOW OR IMPACT.....	9
04 WARNINGS ON USE	9
MAXIMUM TYRE SIZE.....	9
MINIMUM AND MAXIMUM INSERTION LENGTH OF THE SEAT POST.....	9
MAXIMUM FORK LENGTH (AXLE-TO-CROWN).....	9
MAXIMUM NUMBER OF STEERING SPACERS	9
POSITION OF THE SPINDLE INSIDE THE FORK TUBE	9
INTENDED USE	9
05 WARNINGS ON USE OF THE ELECTRICAL ASSISTANCE SYSTEM	10
CARE AND INSTRUCTIONS FOR USE OF THE ELECTRICAL COMPONENTS AND BATTERIES	10
RECOMMENDATIONS TO MAXIMISE THE BATTERY LIFE	10
WARNINGS ON THE USE OF BATTERIES	10
UNSUITABLE CHARGING AND DISCHARGING ENVIRONMENTS AND SOLUTIONS.....	10
RECYCLING.....	10
MOTOR	10
06 PEDAL ASSISTANCE SYSTEM OPERATION	11
COMPONENTS OF THE PEDAL ASSISTANCE SYSTEM	11
PEDAL ASSISTANCE SYSTEM.....	11
PARTS OF THE CONTROL PANEL.....	11
SWITCHING THE PEDAL ASSISTANCE SYSTEM ON AND OFF.....	12
ENCENDIDO Y APAGADO DE LAS LUCES DE LA BICICLETA.....	12
SELECTING THE PEDAL ASSISTANCE MODE.....	12
WALK ASSIST MODE	13
START OF PEDALLING.....	13
DISPLAYING THE BATTERY CHARGE LEVEL.....	14
DISPLAYING THE XPRO BATTERY CHARGE LEVEL.....	14

BATTERY AND CHARGER.....	15
BATTERY CHARGE	15
XPRO BATTERY	17
CHARGING AND DISCHARGING THE XPRO BATTERY.....	17
XPRO BOTTLE HOLDER.....	17
ENERGY SAVING MODES	17
DISPLAY OF SECONDARY INFORMATION ON THE SCREEN.....	18
BATTERY CHARGE LEVEL INDICATOR	18
SETTINGS MENU.....	18
NOTIFICATIONS	20
BLUETOOTH ANT+	20
APP BH BIKES ICONNECT	20
OPERATION WITH THE GARMIN DEVICE	21
SOFTWARE UPDATE OF THE I-REMOTE	22
ERROR CODES	22

07 SIZES AND DIMENSIONS	24
--------------------------------------	-----------

08 TECHNICAL SPECIFICATIONS	25
--	-----------

09 ASSEMBLY AND SPARE PARTS	28
--	-----------

DIMENSIONS OF THE STEERING TUBE	28
BH LITE AHEAD / AERO ACR STEM	30
BH LITE AHEAD / AERO ACR STEM	31
HEADSET.....	32
BUILT-IN BH SEAT POST CLAMP	32
HANGER.....	33
FRONT DERAILLEUR BRACKET	33
MOTOR	34
BATTERY HOLDER.....	35
MOTOR COVER	35
XPRO BOTTLE HOLDER.....	36
SPEED SENSOR MAGNET	36
CHAIN GUARD	37
REAR PADLOCK	37
PANNIER RACK.....	38
CHAIN GUARD FOR CHAINSTAY	38
REAR LIGHT	39
HEADLIGHT.....	39
CABLING OF THE MECHANICAL PARTS	40
CABLING OF THE ELECTRICAL SYSTEM'S PARTS.....	41
WIRING DIAGRAM OF THE ELECTRICAL SYSTEM'S PARTS.....	42
WIRING DIAGRAM OF THE ELECTRICAL SYSTEM'S PARTS.....	43

10 DECLARATION OF CONFORMITY	44
---	-----------

11 HELP AND ADDITIONAL RESOURCES	44
---	-----------

01 INTRODUCTION

This user manual contains important information for proper use and maintenance of the bicycle. In particular, this document contains specific information about the **CORE (EC282, EC262, EC182, EC162, EC642, EC622, EC512, EC502, EC412, EC312, EC242, EC222, EC142, EC122)**. Please read the entire manual carefully. The user manuals of all BH models can be consulted on the website at the following address:

<https://www.bhbikes.com/manuals>

Keep in mind that the manuals on the BH BIKES website are updated on a regular basis. Make sure you have downloaded the latest version from the website. You can check the version on the front page.

This document contains additional information to the general user manual, available at:

https://www.bhbikes.com/es_INT/quienes-somos/manuales-descargas

You can check the characteristics, recommendations and warranties of third-party parts on their corresponding official websites.

SYMBOLS

This document contains different icons that refer to use, maintenance and assembly warnings. Carefully read the meaning of each one to prevent improper handling or hazardous situations that may result in serious personal injuries or fatal accidents.

SAFETY

 **DANGER:** refers to a hazardous situation that, if not avoided, will lead to serious injuries or even a fatal accident.

 **WARNING:** refers to a hazardous situation that, if not avoided, could lead to serious injuries or even a fatal accident.

 **ATTENTION:** refers to a hazardous situation that, if not avoided, could cause minor or moderate injuries.

 **RISK OF ELECTRIC SHOCK:** refers to a hazardous situation that, if not avoided, could cause serious injuries due to electric shock or even death.

 **RISK OF SHORT CIRCUIT:** refers to a hazardous situation that, if not avoided, could cause short circuits in the electrical components. Short circuits may cause damage to the electrical components and fire.

TOOLS



FLAT WRENCH



ALLEN KEY



TORX KEY



PHILLIPS SCREWDRIVER



TIGHTENING TORQUES: on one side of each tool symbol, the tightening torque will be indicated in newton metre.

TYPE OF ASSEMBLY COMPOUND



OIL: light lubrication for elements such as chains and cables.



GREASE: assembly grease.



CARBON PASTE: assembly paste used to increase the friction of the carbon elements.



ADHESIVE: use medium strength thread lock.



Adhesive is used to fasten bolts and make sure that they do not come loose due to vibrations when using the bicycle. Add a drop of thread lock to the tip of the screw thread in all cases. Never apply more than one drop around the thread, since this will make it very hard to remove the bolt.



02 BH WARRANTY

BH BIKES undertakes to offer long-lasting bicycles, in compliance with the highest standards of quality. Therefore, in addition to the statutory warranty, BH BIKES offers an additional coverage and warranty. This section defines the different types of warranty and the process that must be followed to register for the additional "LifeTime Frame" warranty.

STATUTORY WARRANTY

The statutory warranty covers the original purchaser in the event of manufacturing defects and/or non-conformities. This warranty applies to frames and components manufactured by BH BIKES. The warranty period will be established according to the current laws of the country where the bicycle was purchased, and will start on the date of purchase. During this period, the holder of the warranty will be entitled to have all manufacturing defects repaired or replaced free of charge, including the reimbursement of transport expenses and any losses caused as a result of this. Different conditions must be met in order to be covered by the warranty:

- This warranty does not affect the consumer's applicable rights, according to the current laws in each country.
- Faulty bicycles or parts will be covered by warranty upon the decision of our Technical Service.
- The warranty does not include the replacement of parts prone to wear and arising from normal use of the bicycle.
- The warranty does not cover defects or broken parts due to improper use of the bicycle, use for competitions, mounting of non-original accessories or improper handling and incorrect maintenance work.
- The warranty does not apply if the inspection before delivery and the corresponding inspection intervals included in this document have not been carried out, observed, documented as required and stamped by an authorised BH dealer.
- Should the repair not be satisfactory and not ensure that the optimum conditions are met according to the intended use, the holder of the warranty will be entitled to request the replacement of the purchased item or faulty part with one of identical characteristics, or to receive a refund of the amount paid for the damaged item or part.
- The warranty period will be interrupted during the repairs or, in the event of replaced items or components, it will be renewed.
- Any claim against this warranty shall expire six months after the end of the warranty validity period.
- All warranty claims must be processed by an authorised dealer.
- Geographical scope: refer to the User Manual or [www. BHbikes.com](http://www.BHbikes.com)

Visit the following link to read the terms and conditions:

https://www.bhbikes.com/es_INT/registro-garantia-vida-bh/registra-tu-bici-garantia-de-por-vida

LIFETIME FRAME WARRANTY

Through its authorised stores, BH Bikes provides the original buyer with a commercial policy to cover any manufacturing defects in frames for a period beyond that specified in the product's statutory warranty, pursuant to the following clauses:

1. **The LIFETIME warranty solely applies to BH frames and bikes that are sold through stores that are authorised by BHBIKES EUROPE S.L.**
 - The buyer must register the LIFETIME warranty online, with the information duly completed, within 30 calendar days of the purchase date, as it appears on the invoice issued by the authorised store.
 - This warranty cannot be transferred to subsequent buyers and it is cancelled when the bicycle is sold to a third party. Original buyer means the individual who registers the warranty at the time of the purchase; the commercial warranty cannot be transferred to third parties who are not the original buyer.
 - It shall be compulsory to have the bicycle serviced in an establishment that is authorised by BHBIKES EUROPE and according to the instructions in the user manual.
2. **The LIFETIME warranty does not cover:**
 - The rear swingarms of the double suspension models, fork, kids' bikes, defects and/or fading of the original paint, or rust caused by natural deterioration.
 - Defects or breakages resulting from an accident or improper and/or negligent use of the bicycle.
 - When components or accessories that are not intended for or are not compatible with the use for which the bicycle was designed have been installed.
 - Defects resulting from improper handling.
 - Scratches, discolouration, or stains caused by the use of abrasive fluids, sharp items, clamps and/or prolonged exposure to sunlight or other weather conditions.
 - Defects caused by the bicycle's normal wear and tear, including those due to material fatigue. Fatigue damage is a sign that the frame has been damaged by normal use, so it is the user's responsibility to regularly inspect the bicycle.
 - Improper use and/or maintenance of the product (carefully read the recommendations for use and cleaning).
 - Frames that have been used in competitions, demos or as rentals.

Read the full terms and conditions at:

https://www.bhbikes.com/es_INT/registro-garantia-vida-bh/registra-tu-bici-garantia-de-por-vida

EXTENDED WARRANTY OF UP TO 5 YEARS ON BH MOTORS

Activating the LIFETIME FRAME extended warranty will automatically activate a 5-year extended warranty for all BH motors. Through its authorised stores, BH Bikes provides the original buyer with a commercial policy to cover any manufacturing defects in BH motors for a period beyond that specified in the product's statutory warranty, pursuant to the following clauses:

- The BH motor extended warranty solely applies to BH motors installed in BH bikes and sold through stores that are authorised by BHBIKES EUROPE S.L.**
 - The buyer must register the warranty online, with the information duly completed, within 30 calendar days of the purchase date, as it appears on the invoice issued by the authorised store, on which the bike's serial no. must be specified.
 - This warranty cannot be transferred to subsequent buyers and it is cancelled when the bicycle is sold to a third party. Original buyer means the individual who registers the warranty at the time of the purchase; the commercial warranty cannot be transferred to third parties who are not the original buyer.
 - It shall be compulsory to have the bicycle serviced in an establishment that is authorised by BHBIKES and according to the instructions in the user manual.
- The BH motor extended warranty shall not ever cover:**
 - Fading paintwork and a loss of original colour, or corrosion caused by normal wear and tear.
 - Defects or breakages resulting from an accident or improper and/or negligent use of the bicycle.
 - When components or accessories have been installed that are not intended for/compatible with the use for which the bicycle was designed, and when the motor has been tampered with and/or de-limited.
 - Defects resulting from improper handling.
 - Scratches, discolouration, or stains caused by the use of abrasive fluids, sharp items, clamps and/or prolonged exposure to sunlight or other weather conditions.
 - Improper use and/or maintenance of the product (carefully read the recommendations for use and cleaning).
 - Motors that have been used in competitions, demos or in rentals.
 - Motors mounted on bicycles of the MONTY range.

Read the full terms and conditions at:

https://www.bhbikes.com/es_INT/registro-garantia-vida-bh/registra-tu-bici-garantia-de-por-vida

EXTENDED WARRANTY FOR BH BATTERIES

In a constant effort to improve our customer services on a daily basis, BH offers the best warranty conditions and the possibility of acquiring an extended warranty for its e-Bike range (an additional one or two years). Through its authorised stores, BH Bikes provides the original buyer with a commercial policy to cover any manufacturing defects in BH batteries for a period beyond that specified in the product's statutory warranty, pursuant to the following clauses:

- The BH battery extended warranty solely applies to BH batteries installed in BH bikes and sold through stores that are authorised by BHBIKES EUROPE S.L:**
 - The buyer must register the warranty online, with the information duly completed, within 30 calendar days of the purchase date, as it appears on the invoice issued by the authorised store, on which the bike's serial no. must be specified.
 - This warranty cannot be transferred to subsequent buyers and it is cancelled when the bicycle is sold to a third party. Original buyer means the individual who registers the warranty at the time of the purchase; the commercial warranty cannot be transferred to third parties who are not the original buyer.
 - It shall be compulsory to have the bicycle serviced in an establishment that is authorised by BHBIKES and according to the instructions in the user manual.
- The BH battery extended warranty shall not ever cover:**
 - Fading paintwork and a loss of original colour, or corrosion caused by normal wear and tear.
 - Defects or breakages resulting from an accident or improper and/or negligent use of the bicycle.
 - Deterioration or natural degradation due to age, even without use. Deterioration after 500 full charging and discharging cycles if it is below 30% of the nominal capacity (read the recommendations in the user manual carefully).
 - When components or accessories have been installed that are not intended for/compatible with the use for which the bicycle was designed.
 - Defects resulting from improper handling.
 - Scratches, discolouration, or stains caused by the use of abrasive fluids, sharp items, clamps and/or prolonged exposure to sunlight or other weather conditions.
 - Improper use and/or maintenance of the product (carefully read the recommendations for use and cleaning).
 - Batteries that have been used in competitions, demos or in rentals.
 - Auxiliary batteries (extenders).

Read the full terms and conditions at:

https://www.bhbikes.com/es_INT/registro-garantia-vida-bh/extension-garantia-bateria

REGISTERING EXTENDED WARRANTIES

You must register the bicycle within 30 days after purchase to enjoy the BH BIKES additional warranties. The process to activate the extended warranties is described below:

- **LIFETIME FRAME WARRANTY + 5 YEARS WARRANTY ON BH ENGINES**

You must register the bicycle on the BH BIKES website to enjoy the LIFETIME FRAME extended warranty:

https://www.bhbikes.com/es_INT/registro-garantia-vida-bh/registra-tu-bici-garantia-de-por-vida

Watch this video to find out what you need to do:

<https://youtu.be/47aLVgUI248>



- **EXTENDED WARRANTY FOR BH BATTERIES**

You must register the bicycle on the BH BIKES website to enjoy the BH BATTERY extended warranty:

https://www.bhbikes.com/es_INT/registro-garantia-vida-bh/extension-garantia-bateria

Watch this video to find out what you need to do:

<https://youtu.be/sINzdFBygMM>



- ⚠ The serial number required to register the bicycle is located on the bottom of the bicycle, under the bottom bracket:

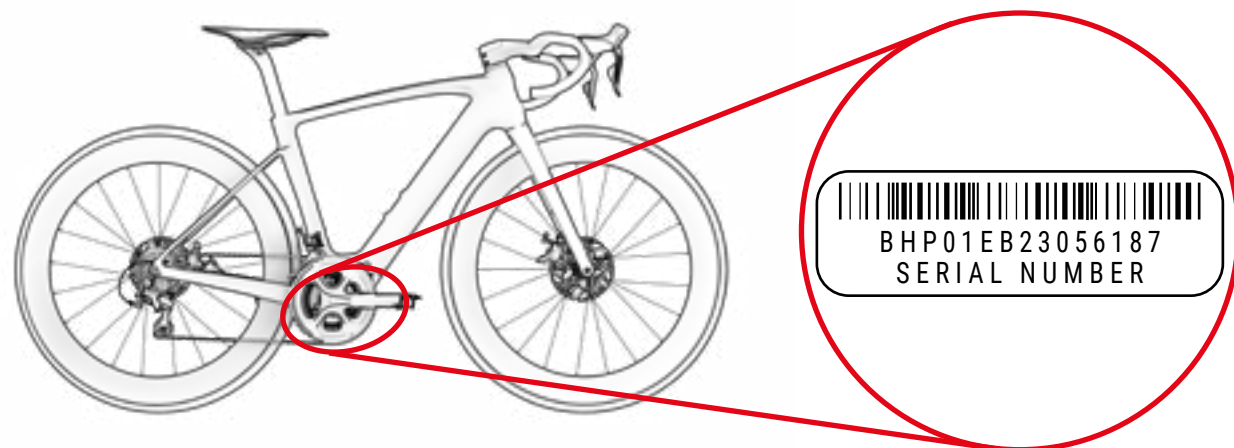

WARRANTY OF PARTS OF THE ELECTRICAL ASSISTANCE SYSTEM

As in the case of BH BIKES frames and parts, all electrical components made exclusively for BH will be covered by the statutory warranty (BH motors feature an extended 5-year warranty after the LIFETIME FRAME warranty is activated). The warranty period will be established according to the current laws of the country where the bicycle was purchased, and will start on the date of purchase.

During this period, the holder of the warranty will be entitled to have all manufacturing defects repaired free of charge, including the reimbursement of transport expenses and any losses caused as a result of this. The terms and conditions are as described in the section "Statutory Warranty" and can be read at:

<https://www.bhbikes.com/manuals>

Under no circumstances shall the warranty cover the wear and natural ageing of batteries due to use, charging and storage. Likewise, the buyer must contact the original manufacturer to use the warranty of third-party parts.

SUBMITTING A WARRANTY CLAIM

All warranty claims must be channelled through an official BH dealer. The dealer will analyse the claim to identify its scope and perform a preliminary assessment of the incident. The dealer will submit and process the claim directly with BH. Once BH has defined the corrective measures required, the dealer will send this information to the customer.

All claims must be processed by the official dealer from which you purchased your bicycle. If this is not possible, please contact us directly. We will help you find an authorised dealer near you:

https://www.bhbikes.com/es_INT/quienes-somos/contacto

CONDITIONS THAT MAY VOID THE WARRANTY OF ELECTRICAL COMPONENTS

The BH battery and electrical components are covered by the statutory warranty, but the following requirements must be met:

- No electrical components must be removed or tampered with.
- The service life will vary according to the use, charging and storage conditions.
- Keep the battery charged at all times. Otherwise, the battery may deteriorate faster than normal.

03 MAINTENANCE

This user manual contains important information for **CORE (EC282, EC262, EC182, EC162, EC642, EC622, EC512, EC502, EC412, EC312, EC242, EC222, EC142, EC122)**. Please read the entire manual carefully. The user manuals of all BH models can be consulted on the website at the following address:

<https://www.bhbikes.com/manuals>

This document contains additional information to the general user manual, available at:

<https://www.bhbikes.com/manuals>

You can check the characteristics and recommendations of third-party parts on their corresponding official websites.

INSPECT THE BICYCLE BEFORE USE

Bicycles are inspected several times throughout the manufacturing process and then at the BH workshop during the final check. As the bicycle's operation may be affected during transport or third parties may have modified the bicycle before its sale, the following must be checked before each trip:

- **FRAME:** no cracks, damage or strange noises.
- **CHAIN:** it must be lubricated and the transmission system must not make any strange noises.
- **BRAKES:** the brakes must be working properly. When stopped, press the brake lever with enough strength and check that it does not touch the handlebars.
- **TYRES:** the pressure must be correct and there must be no cuts on the tread or on the sides. Also check that the wear level does not exceed the maximum recommended level.
- **WHEELS:** the wheels must rotate freely in order to check how they rotate. Also check the space between the brake lining and the rim, as well as the space between the frame and tyre.
- **STEERING:** the steering must turn smoothly and with no strange noises.
- **SWINGARM ROTATION POINTS:** when weight is exerted on the bicycle, the suspension must work as expected and with no strange noises. If it is not working properly or there is play between the moving parts, this might mean that the tightening torques are incorrect or that the bearings are worn.
- **BEARINGS:** the bearings must work properly and with no strange noises. The bearings are subject to wear and must be replaced to prevent damage to the components on which they are installed.
- **ELECTRICAL SYSTEM:** if the bicycle features an electrical system, check that it is functioning properly by ensuring that the electrical assistance mode is running and that all parts are functioning properly (motor, display, change of assistance mode and speed sensor). If there is no electrical assistance, check that all connections are correct and show no signs of damage.

 Do not ride your bicycle if it does not meet any of these points! A faulty bicycle may cause serious accidents! If you are unsure or have any queries, please contact your nearest BH workshop!

 Check the tightening torques to make sure that they are as described in the recommendations in the user manuals. Failure to observe these recommendations may result in accidents and even death.

 The effect of the ground and the forces exerted on the wheel subject the bicycle to a lot of stress. The different parts will be subject to fatigue and wear because of these dynamic loads. Check the bicycle at regular intervals to look for signs of wear, scratches, bent parts, wear on the finish or the formation of cracks. Parts may fail suddenly after their service life has expired. Take your bicycle to an authorised BH workshop regularly to have these parts replaced if needed.

KEEP THE BICYCLE CLEAN

We recommend you follow these basic prevention measures to make sure that the bicycle is in perfect working order. Failure to observe these recommendations may lead to premature wear or even breakages in specific areas, such as gaskets or moving parts.

- Clean the dust and mud with a damp sponge and a gentle and neutral cleaning product.
- Plastic parts must only be washed with soapy water.
- Tyres can be washed with a sponge or brush and soapy water.
- After cleaning the bicycle, dry it by rubbing it firmly with a smooth cloth.
- After each cleaning, lubricate the transmission elements.

 Dirt may cause damage that can result in accidents or even death.

 Never use pressure washers or steam cleaners.

KEEP THE TRANSMISSION LUBRICATED AT ALL TIMES

After washing the bicycle, the chain transmission's lubrication may have also been washed off. Inspect and lubricate the chain's links, if needed. Excess lubrication may attract more dirt, causing premature wear and incorrect functioning of the system.

 Never use pressure washers or steam cleaners.

PART MAINTENANCE

The bicycle requires regular maintenance and a minimum number of regular inspections. The frequency of the maintenance operations depends on the type of vehicle (leisure, road or mountain bike), as well as the frequency and conditions of use.

PART MAINTENANCE CALENDAR

Part	Action required	Before each outing	Monthly	Annually
Lighting	Functional check.			
Tyres	Pressure check.			
	Inspect the height of the profile and sides.			
Brakes (on the rim)	Check the lever travel, lining strength and rim position.			
	Brake test when stopped.			
	Clean the brake pads.			
Brake cables	Visual inspection.			
Brakes (disc brakes)	Change the brake fluid (DOT fluid).			
Suspension fork	Check the bolts and the corresponding tightening torque.			
	Change the oil and lubricate the elastomer.			
Saddle seat post with suspension	Maintenance.			
	Play check.			
Rims on rim brakes	Inspection and replacement, if needed, of the wall linings.	At the latest after the second part of the brake lining.		
Bottom bracket axle	Check the play.			
	Re-lubrication.			
Chain	Check and lubrication.			
	Check and replacement.	After 800 km.		
Chainsets	Check and tightening.			
Wheels / Spokes	Check wheel spin and spoke tension.			
Headset	Inspection of the headset.			
	Re-lubrication.			
Metal surfaces	Maintenance.	At least once every six months.		
Hubs	Bearing inspection.			
	Re-lubrication.			
Pedals	Bearing inspection.			
	Lubrication, cleaning the anchoring mechanism.			

Part	Action required	Before each outing	Monthly	Annually
Saddle seat post / Stem	Inspection of the fastening screws.			
Rear derailleur / Derailleur	Cleaning, lubrication.			
Quick-release mechanism / Thru-axle	Efficacy check.			
Nuts and bolts	Check and tightening.			
Spokes	Tension check.			
Stem / Saddle seat post	Removing and applying new assembly paste.			
Circuit / Brakes	Disassembly and greasing.			
	Check the connections.			
Components of the electrical assistance system	Check there is no dirt.			

 You do not need to take the bicycle to an expert if you are skilled, experienced and have the appropriate tools. Immediately implement the corrective measures if you detect problems. If you are unsure or have queries, please contact BH.

 The tasks described above must only be carried out by a trusted bike repair expert.

SPARE PARTS

Original parts must be used to ensure the optimum performance of your bicycle and the utmost safety. Failure to use original parts may cause damage that is not covered by the warranty.

The most common spare parts are parts prone to wear. The most common ones are tyres, inner tubes, brake pads, disc brakes and brake pads, as well as rims, when these are part of the brake unit, headlights, position lights, batteries and accumulators.

- **TYRES:** Replace them with an equivalent type of tyre. Check the marking on the outside of the tyre (ETRTO standard). Keep in mind that using a tyre with a larger outer diameter than the recommended one may cause the tip of the foot to touch the front wheel or rear wheel guard when the handlebars turn. The cyclist may lose control of the bicycle and suffer an accident with serious consequences. This can also occur when the pedal chainset is replaced with a longer one.
- **INNER TUBES:** Replace them with a suitable type of inner tube, according to the type of tyre. Refer to the information on the outside of the inner tube (ETRTO standard).
- **DISC BRAKES AND BRAKE PADS:** Follow the instructions supplied by the manufacturer.
- **HEADLIGHTS AND POSITION LIGHTS:** Replace the bulb with one of the same type. Check the indication on the metal area.

- **CHAIN, COG AND CHAIN RINGS:** Follow the instructions supplied by the manufacturer.
- **BATTERIES AND ACCUMULATORS:** Change for the same type. Check the indication on the outer area.

 Remember that the failure to use original parts may cause damage that is not covered by the warranty.

AFTER A FALL, BLOW OR IMPACT

If you suffer a fall, blow or impact, first make sure that you are okay to continue cycling. Do not use the bike if you are injured and ask for medical assistance if needed.

If you are okay to continue cycling, check the bicycle to make sure that it is in perfect working order:

- Check that the wheels are firmly secured and that the rims are in the centre of the frame and fork. Turn the wheels. If they cannot be centred in situ because the gap is too small, separate the brakes from the rim so it can move freely.

 In this case, keep in mind that the braking efficacy will be less.

- Check whether the handlebars or the front of the frame are twisted or broken. Check that the front is firmly seated on the fork, holding the front wheel firmly between your legs and trying to twist the handlebars with respect to the front wheel.
- Check that the chain is fitted correctly. If the bicycle fell onto the transmission side, check that it is working properly. Ask for help to place the bicycle on its saddle and change gears. When the chain fits on the largest cog, check the distance between the gear and the spokes. If the gear or bracket are bent, the first one may become stuck on the spokes - Danger of falling! The gear, rear wheel or frame may be damaged. Check the derailleur. If it has shifted, the chain may come off the gear. The bicycle's transmission will become less effective (also refer to the "Traction" section).
- Check the saddle, upper tube or the bottom bracket box to make sure that there are no defects.
- Lift the bicycle slightly and let it drop onto the ground. If there are any noises, inspect the bicycle for any loose bolts.
- Inspect the entire bicycle again to check for bent areas, worn finish or cracks.
- Ride again carefully if no problems have been detected during the inspection. Do not brake or accelerate suddenly or pedal when going uphill. If you are unsure, wait for a car to pick you up instead of risking an accident. Once home, you should inspect the bicycle carefully again. If you are still unsure or have any queries, please contact your nearest BH workshop!

 Bent aluminium parts must not be straightened, i.e., they must not be repaired. Even afterwards, there is a high risk of breakage, especially in regards to the fork, handlebars, front part, chainsets and pedals. Replace them for greater safety.

04 WARNINGS ON USE

MAXIMUM TYRE SIZE

If you install a tyre of a different size on your bicycle, check and make sure that there are at least 6 mm between the tyre and other parts of the frame and fork.

MINIMUM AND MAXIMUM INSERTION LENGTH OF THE SEAT POST

Failure to observe the maximum and minimum seat post insertion dimensions indicated in this manual may cause a lever effect on the frame. The pressure exerted could damage the frame and cause serious accidents. The warranty does not cover the damage generated by failing to observe these indications.

MAXIMUM FORK LENGTH (AXLE-TO-CROWN)

Observe the maximum length between the fork axle and the lower part of the steering tube (axle-to-crown). If this maximum length is not observed, the frame could be damaged due to withstanding a greater load than that for which it was designed and may cause serious accidents.

MAXIMUM NUMBER OF STEERING SPACERS

This manual specifies the maximum number of steering spacers that can be fitted under the stem. If this maximum quantity is not observed, the materials could be damaged due to withstanding a greater load than that for which they were designed and may cause serious accidents.

POSITION OF THE SPINDLE INSIDE THE FORK TUBE

No steering spacers must be fitted above the stem. Otherwise, the materials could be damaged due to withstanding a greater load than that for which they were designed and may cause serious accidents.

INTENDED USE

Each bicycle has been designed according to a specific intended use. The models described in this manual meet the requirements associated with their intended use:

EC282, EC262, EC242, EC222: Gravel.

EC182, EC162, EC142, EC122: Road.

EC642, EC622: Sport.

EC512, EC502, EC412, EC312: Town/City.

05 WARNINGS ON USE OF THE ELECTRICAL ASSISTANCE SYSTEM

CARE AND INSTRUCTIONS FOR USE OF THE ELECTRICAL COMPONENTS AND BATTERIES

All BH products and parts have been designed to withstand splashed liquids and rain. However, some practices may cause damage to the parts and short circuits. Do not do the following:

- Wash the bicycle with pressure devices.
- Use the bicycle under adverse weather conditions.
- Transport the bicycle on the outside of a vehicle when it is raining.
- Expose the batteries to very high temperatures. If the temperature exceeds 70°C, this could cause leaks and there could be a risk of fire.
- Fail to observe the working temperature, storage and charging range of the bicycle.

RECOMMENDATIONS TO MAXIMISE THE BATTERY LIFE

We recommend the following to maximise the battery life:

- Charge it on a flat and stable surface.
- Make sure that it is not exposed to direct sunlight.
- Make sure that there are no children or pets near.
- Make sure that there is no rain or dampness.
- The place must be well ventilated and dry.
- The temperature must be between 15-25°C.
- Do not use the battery with a charge of less than 10%. The useful life of the cells may be affected below this charge level.

 Any unauthorised handling of the electrical system's components may cause serious accidents and will void the warranty.

WARNINGS ON THE USE OF BATTERIES

Improper use of the batteries may cause damage and serious accidents. Follow these recommendations to prevent this:

- Always use the original battery charger.
- Never leave the battery near sources of heat.
- Do not heat the battery or throw it into a fire.

- Prevent the battery connections from coming into contact with metal objects.
- Do not submerge the battery in water and prevent splashes and dampness.
- Do not hit or drill holes into the battery.
- Make sure that the battery liquid does not touch your hands or eyes in the event of a leak.
- Do not use it if there are external signs of damage.
- Only clean the battery with a dry or damp cloth.

UNSUITABLE CHARGING AND DISCHARGING ENVIRONMENTS AND SOLUTIONS

The hot and cold environments described below may lead to charging entering standby or sleep mode without fully charging the battery.

- **Winter discharging sleep mode or DUT (Discharge Under Temperature):** Battery discharging will enter the deep sleep mode if the temperature is below -20°C, stopping the pedal assistance system from working and protecting the battery. In such cases, sleep mode will automatically be disabled when the battery exceeds -20°C.
- **Winter charging sleep mode or CUT (Charge Under Temperature):** Battery charging will enter sleep mode if the temperature is below 0°C. If charging starts and the temperature falls below this level due to night cooling or other factors, charging will stop and sleep mode will be activated to protect the battery. In such cases, sleep mode will automatically be disabled when the battery exceeds 0°C.
- **Noise on televisions/radios/computers:** Charging near televisions, radios or similar devices may cause static electricity, flickering images and other interference. If this happens, recharge somewhere that is away from the television or radio (e.g. in another room).

RECYCLING

Ion-lithium batteries can be recycled but they may harm the environment if they are not managed properly after the end of their service life. Follow these steps after the end of their service life:

- Classify and recycle each electrical component in a place prepared for the sustainable recycling of such parts.
- Check and make sure that the applicable regulations of your country are observed with regards to batteries.

MOTOR

The DC motor is located on the bottom bracket axle. The motor's service life depends on its use, as in the case of any other part of the bicycle. Under normal conditions, the motor can last for 10 to 20 years, or up to 100,000 km.

06 PEDAL ASSISTANCE SYSTEM OPERATION

COMPONENTS OF THE PEDAL ASSISTANCE SYSTEM

The BH Bikes pedal assistance system is made up of the following components:

- **A. A motor**, which drives the bicycle.
- **B. A control panel** (X-REMOTE in models with X-DISPLAY, built into models with CORE DISPLAY), which, among other things, allows you to select the assistance mode.
- **C. A battery**, which powers the motor.
- **D. A torque sensor**, which reads the force applied to the pedal by the user.
- **E. A display** (CORE DISPLAY or X-DISPLAY), which shows relevant system information.

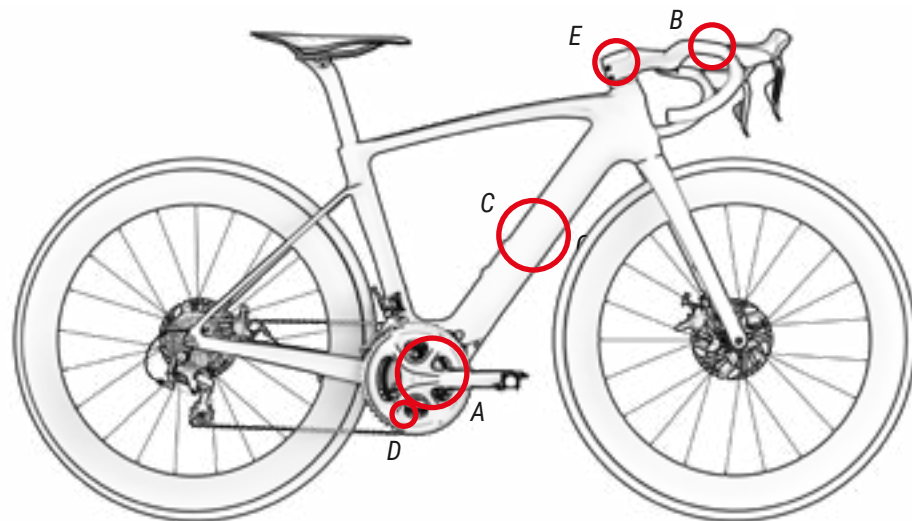

PEDAL ASSISTANCE SYSTEM

The pedal assistance system is designed to provide the optimal amount of assisted power. It provides assistance within a standard range, based on factors such as the pedalling force, the speed of the bicycle and the transmission.

The system does not provide assistance in the following situations:

- If the control panel is off.
- When travelling at 25 km/h or faster.
- If you are not pedalling and the throttle function is released at 6 km/h.
- If there is no remaining battery capacity.
- If the assistance mode selected is 0% assistance.

PARTS OF THE CONTROL PANEL

EC282 / EC262 / EC182 / EC162 / EC242 / EC222 / EC142 / EC122

The Core display is made up of a ring with 12 LEDs and a button inside the ring, used as the control panel:

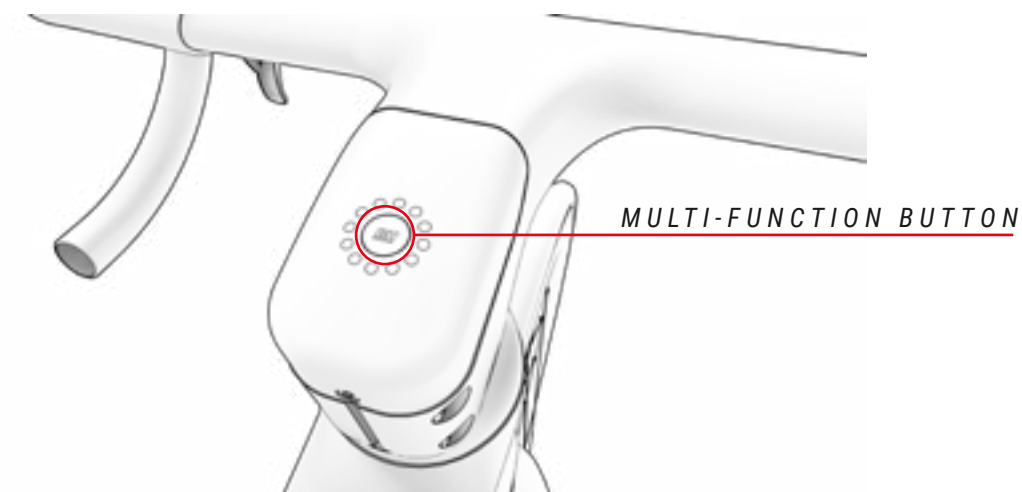

EC642 / EC622 / EC512 / EC502 / EC412 / EC312

The X-Remote (general control panel) is located on the left side of the handlebars, next to the grip. The control consists of 3 parts:

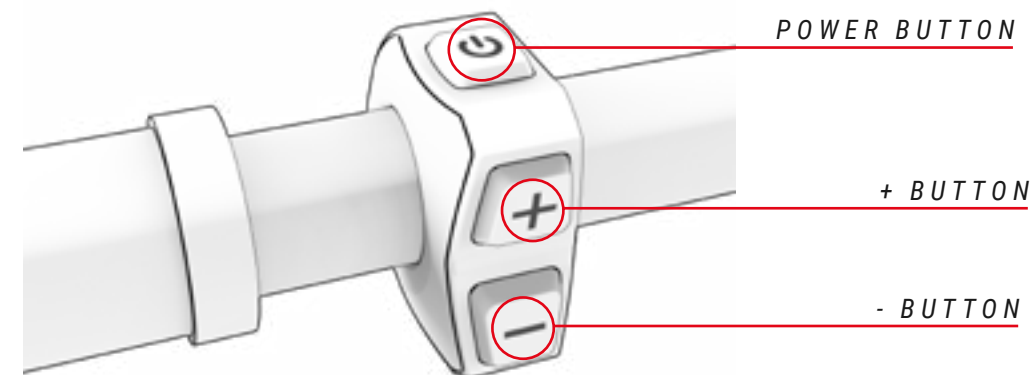

SWITCHING THE PEDAL ASSISTANCE SYSTEM ON AND OFF

EC282 / EC262 / EC182 / EC162 / EC242 / EC222 / EC142 / EC122

The pedal assistance system is activated from the Core display. It is located on the bicycle's stem. Press the power button to start the system. The Core display will be lit, showing a blue animation moving counterclockwise. The current pedal assistance mode will be shown next.

To disconnect the pedal assistance system, press and hold the multi-function button for 3 seconds. The screen will turn off and the system will shut down.



EC642 / EC622 / EC512 / EC502 / EC412 / EC312

The pedal assistance system is switched on from the X-Remote (central control panel). It is located next to the left grip on the handlebars. Press the power button to start the system. The X-Display will turn on showing the current pedal assistance mode.

To turn off the pedal assistance system, press and hold the power button for 3 seconds. The screen will turn off and the system will shut down.



- ⚠ After turning the system on, make sure that you do not start riding without checking the assistance mode. By default, it starts with the assistance mode selected before it was last switched off.
- ⚠ Wait for 3 seconds after turning on the system before you start applying pressure on the pedals. During this 3-second period, the assistance system is starting up and calibrating the torque sensor. Otherwise, if you press the pedals beforehand, this may reduce the effectiveness of the assistance system and error 14 may even be displayed on the screen (see the "Error code" section). To fix this, you should reboot the system without applying pressure to the pedals for the 3-second period.

ENCENDIDO Y APAGADO DE LAS LUCES DE LA BICICLETA

EC512 / EC502 / EC412 / EC312

When you press and hold the (-) button for 3 seconds, lights are switched on and off in those models equipped with a battery-powered light system.

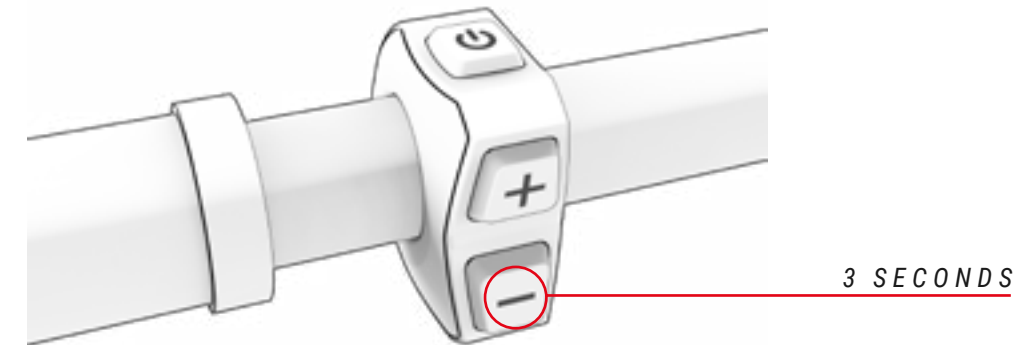

SELECTING THE PEDAL ASSISTANCE MODE

The system features the following pedalling assistance modes:

- **Boost:** Identified by the colour **Red**. Use when you want to get peak power from the system.
- **Sport:** Identified by the colour **Orange**. Use when climbing difficult terrains.
- **Eco+:** Identified by the colour **Blue (disabled from factory on models with CORE DISPLAY)**. Use when you want a more comfortable ride, e.g. when climbing a steep hill. It can be activated from the BH iConnect app, adding an assistance percentage value other than 0.
- **Eco:** Identified by the colour **Green**. Use when you want to travel as far as possible.
- **No assist:** Identified by the colour **White**. Use when you want to travel without assisted power. You can continue to use the other functions of the control panel.

To toggle through the assistance modes, the user must press the (+) button to increase the level of assistance and the (-) button to reduce the level of assistance.

EC282 / EC262 / EC182 / EC162 / EC242 / EC222 / EC142 / EC122

To scroll through the different assistance modes, the user must press the multi-function button once to increase the level of assistance and twice to decrease it.

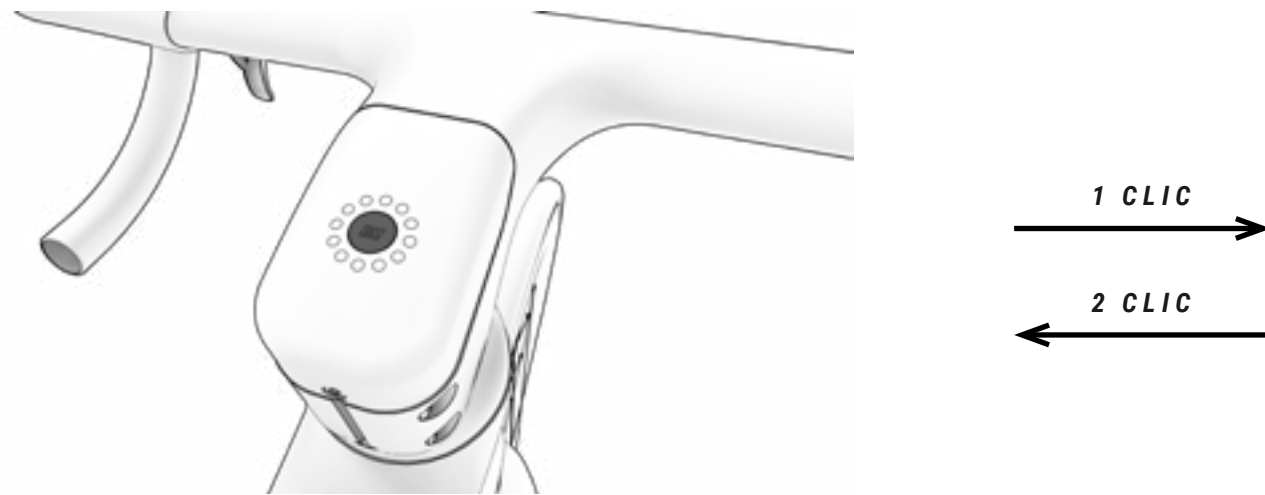

EC642 / EC622 / EC512 / EC502 / EC412 / EC312

To toggle through the assistance modes, the user must press the (+) button to increase the level of assistance and the (-) button to reduce the level of assistance.

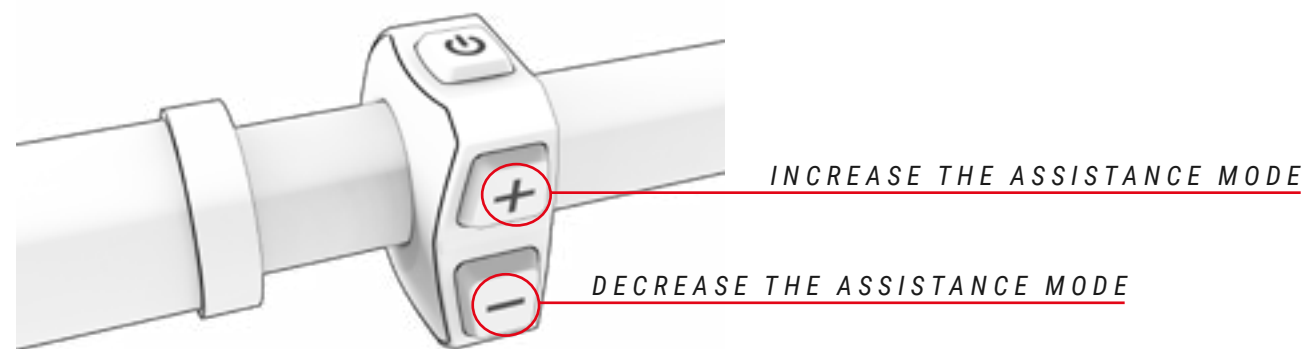

In order to increase the life of the battery and prevent a full discharge which may damage it, the assistance modes are limited based on the state of charge of the battery:

- Battery charge above 20%: 100% of the highest assistance level is available.
- Battery charge between 10% and 20%: assistance level limited to 50% of the highest assistance level.
- Battery charge between 5% and 10%: assistance level limited to 25% of the highest assistance level.
- Battery charge between 1% and 5%: assistance is not permitted. Only the lights can be turned on.

WALK ASSIST MODE EC642 / EC622 / EC512 / EC502 / EC412 / EC312

The walk assist mode helps the user to transport the bike by foot. To activate this mode, press and hold the + button on the control panel (it doesn't matter which assistance mode is selected when the + button is pressed). The LEDs on the X-Remote control panel will flash blue, indicating that this mode has been activated. Release the + button to exit this mode.

START OF PEDALLING

Before resting your feet on the pedals, you must sit on the saddle and hold the handlebars firmly. Special care should be taken if you start pedalling when using a high assistance mode (TRACK and BOOST modes), as the motor will respond with maximum thrust and you may lose control. To facilitate acceleration, the motor provides an additional initial thrust as soon as you start pedalling. Therefore, minimal force is required to put the bicycle in motion, helping you to join the traffic quickly and safely.

- ⚠ Start pedalling with a short gear ratio (higher gears) and low assistance mode (ECO mode). As well as providing greater control and safety on the bicycle, it requires less energy consumption and, therefore, ensures a longer range. Starting to pedal with a higher assistance mode (TRACK and BOOST modes) may put the user at risk.
- ⚠ When the user pushes the bike while walking alongside it, they must make sure that the system is disconnected.

DISPLAYING THE BATTERY CHARGE LEVEL

A 100% charge can provide a range of up to 165 km. The battery charge level can be displayed in different ways. The battery charge level indicator shows the estimated remaining battery capacity in all cases:

- **Garmin devices:** Garmin devices also display the battery level on their interface:



EC282 / EC262 / EC182 / EC162 / EC242 / EC222 / EC142 / EC122

In models equipped with the Core display, the battery charge level will be shown with the ring of LEDs. The current battery level can be interpreted according to the number of LEDs that are lit. Keep in mind that the colour shown only refers to the current assistance mode.

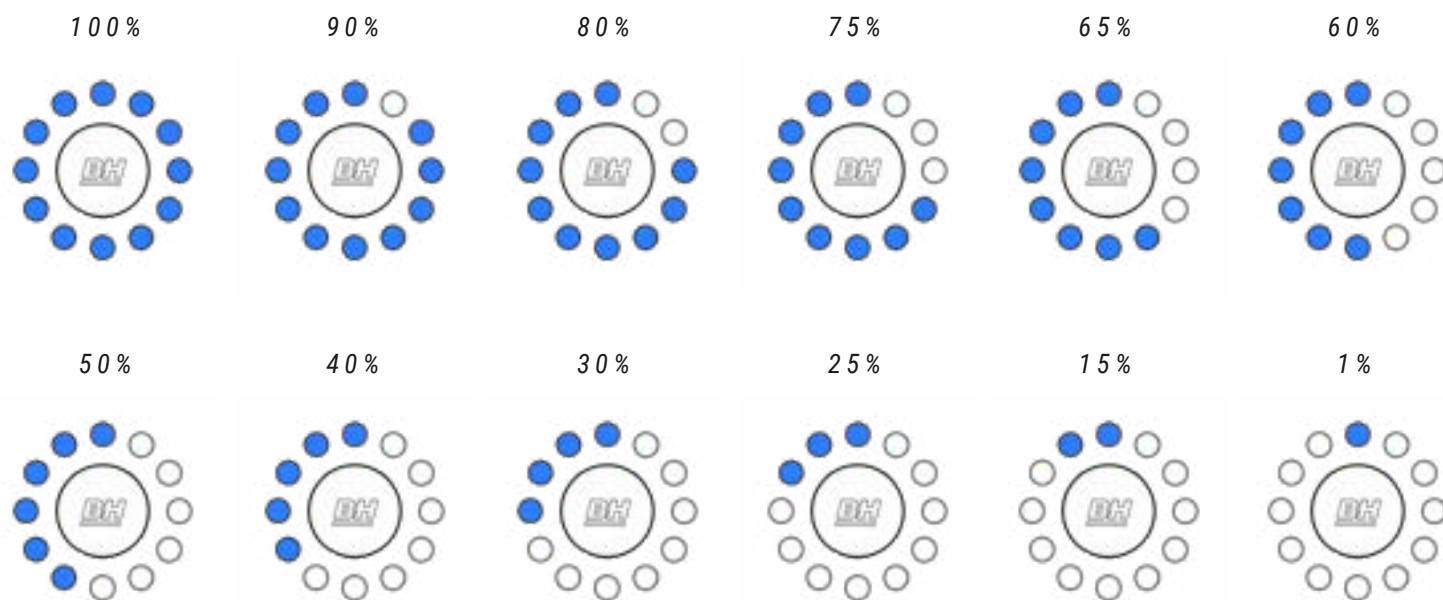

EC642 / EC622 / EC512 / EC502 / EC412 / EC312

In models equipped with the X-Display, the battery charge level will be shown on the top left of the display.



- ⓘ The range of the system will vary depending on the following riding conditions, among others: frequent starts and stops, transmission ratio, numerous steep slopes, road surface in poor condition, carrying heavy loads, strong wind coming towards the cyclist, low temperatures, degradation of the battery, use of the built-in lighting system, incorrect tyre pressure, chain or brake settings.

DISPLAYING THE XPRO BATTERY CHARGE LEVEL

The XPRO external battery boosts the standard 160 km range up to 220 km. By pressing the XPRO battery button, a ring will be lit around the button. The colour of this ring indicates the XPRO battery charge level. Green 100-75%, blue 75-50%, yellow 50-25%, red 25-10% and flashing red 10-0%.

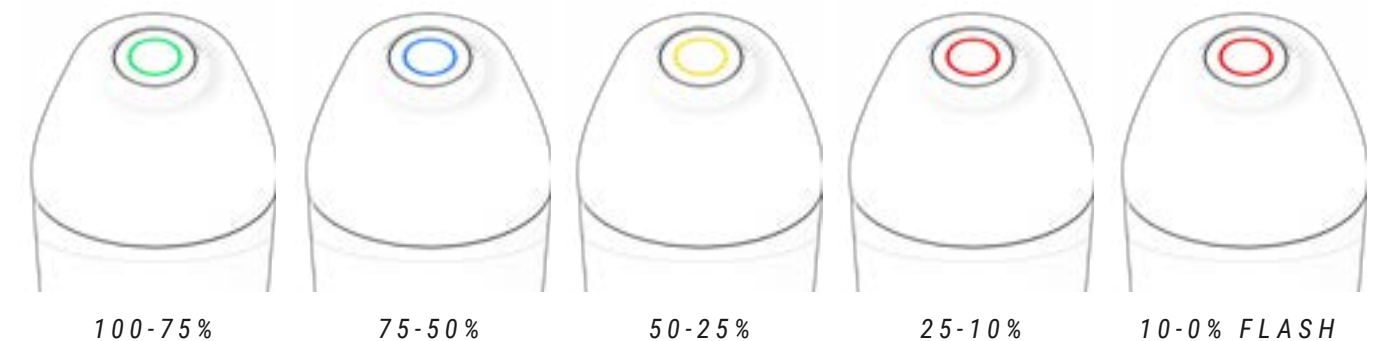

EC282 / EC262 / EC182 / EC162 / EC242 / EC222 / EC142 / EC122

In models equipped with the Core display, the XPRO battery charge level will be shown with the ring of LEDs. The capacity of the XPRO battery will be added to the capacity of the bicycle's internal battery and the display will show the total charge of both batteries as follows:

If both batteries have a full charge (100%), the excess capacity of the sum of both batteries over the nominal capacity of the internal battery will be indicated by displaying 1-4 LEDs in a different colour to the selected assistance mode.

The LEDs will start to be lit according to the extra charge level, starting with the top LED and continuing up to the fourth LED in counterclockwise direction. The colour indicating additional charge will not always be the same colour. The colour of these LEDs will vary according to the selected assistance mode, ensuring that there is a greater contrast with the colour of each level of assistance.

12+4 LEDS
720WH



12+2 LEDS
630WH



6 LEDS
270WH



EC642 / EC622 / EC512 / EC502 / EC412 / EC312

On the X Display, if both batteries are charged, the excess capacity of the sum of both batteries over the nominal capacity of the internal battery will be indicated by the battery bar in blue and a % above 100% being displayed.

The battery icon will show the XPro battery's additional capacity.

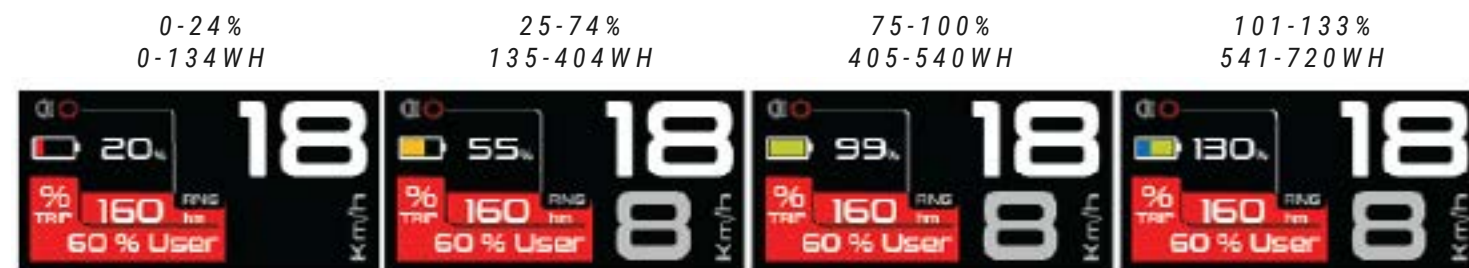

BATTERY AND CHARGER

The battery that your BH bike is equipped with contains lithium-ion cells and is the most advanced technology available in terms of energy density (energy stored per kilogram of weight and per cm³ of volume).

Lithium-ion batteries have the following characteristics:

- Their performance decreases in extremely hot or cold environments.
- An additional characteristic of BH's lithium-ion batteries is that they have no "memory effect", and are not affected by incomplete discharging.
- They lose their charge naturally and gradually with use. The battery can be fully discharged (100%) approximately 500 times, with maximum battery deterioration of 20%. In the case of partial discharges, only the discharged part is counted. For example, if you charge the battery every time its charge level falls by 25%, you will be able to charge it to 100% of its initial capacity 2,000 times. In short, the guaranteed durability of the battery with maximum degradation of 20% is at least 20,000 km.

BATTERY CHARGE

Due to its advanced lithium-ion technology, there is no need to wait for the battery to completely discharge before connecting it to the charger. Likewise, it is also not necessary to charge it to 100% before using it again. But bear in mind that, in order to achieve a maximum operating range, a full charge is recommended.

1. TURN ON THE DISPLAY. IT WILL NOT CHARGE IF THE DISPLAY IS OFF.

EC282 / EC262 / EC182 / EC162 / EC242 / EC222 / EC142 / EC122

EC642 / EC622 / EC512 / EC502 / EC412 / EC312

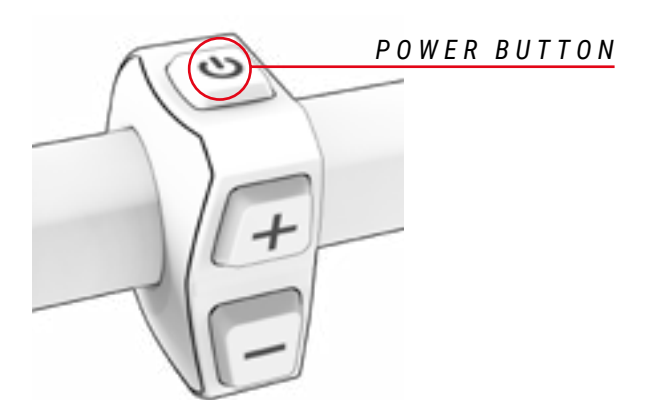

2. OPEN THE COVER OF THE CHARGING PORT ON THE LOWER LEFT SIDE OF THE FRAME.



3. CONNECT THE BATTERY FIRST AND THEN PLUG INTO THE POWER SOCKET.

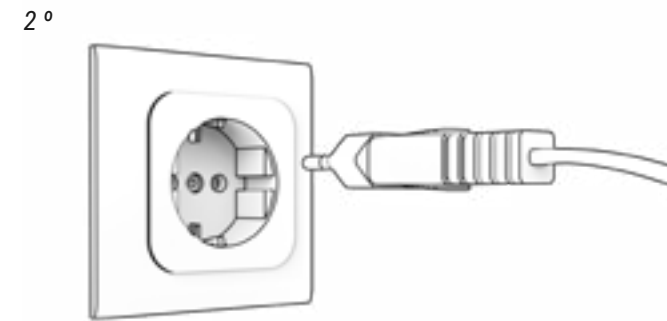
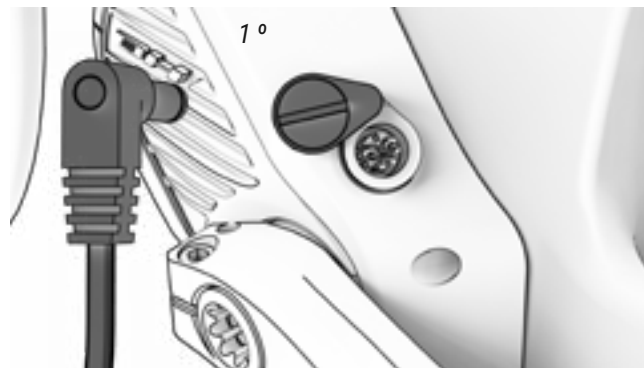

6. CAREFULLY CLOSE THE CHARGING PORT COVER, MAKING SURE NO DIRT OR WATER ENTERS.





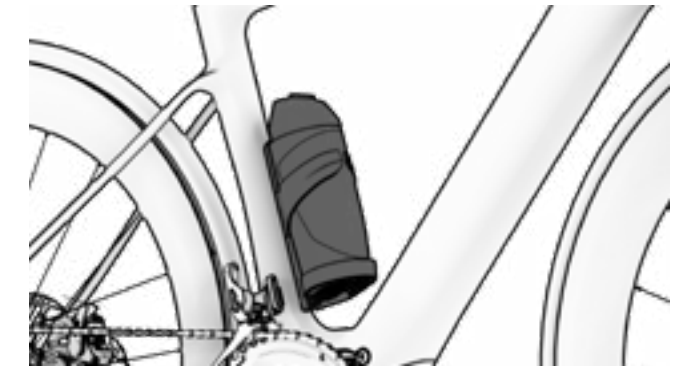

7. THE XPRO BATTERY WILL BE CHARGED IF IT IS IN THE BOTTLE HOLDER AND THE BICYCLE IS CHARGING, WITH THE DISPLAY ON.











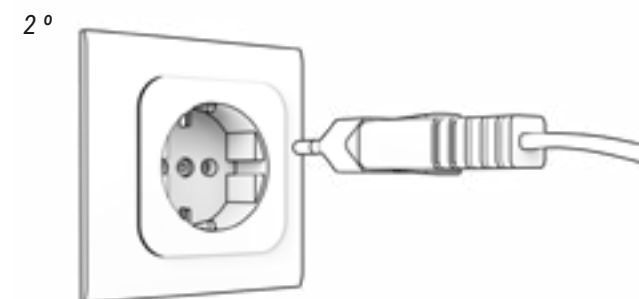
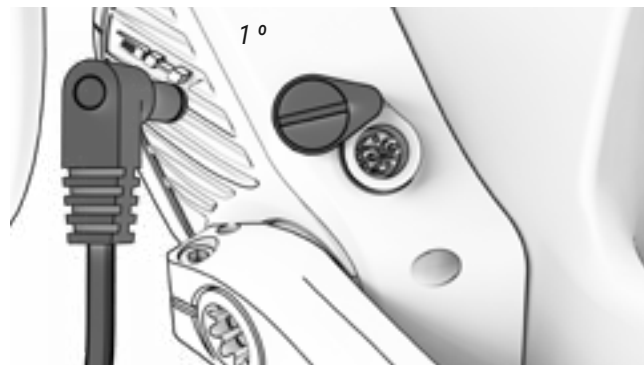

4. VIEW THE STATE OF CHARGE AND ERRORS.



-  100% CHARGED
-  CHARGING
-  STANDBY (FLASH)
-  CHARGING PROBLEM (FLASH)

5. ALWAYS DISCONNECT THE BATTERY CHARGER FIRST AND THEN REMOVE THE PLUG FROM THE POWER SOCKET.



-  Never charge or use a damaged battery.
-  Be careful not to touch the charger during the charging process. It may be hot, especially in high ambient temperatures.
-  If a fault occurs while the battery is being charged, remove the charger's power plug from the socket and wait for the battery to cool down.
-  Never touch the power plug, charging plug or contacts with wet hands.
-  Make sure that there is no foreign matter on the battery's contacts before placing it on the bicycle.
-  Do not connect the charger's power plug to the battery or bicycle's charging port if it is wet or damp. Make sure that you only connect the power plug when the battery or bicycle's charging port is completely dry.
-  Do not apply excessive force on the power plug or pull the cable with the power plug connected to the battery.
-  Turn off the pedal assistance system before removing the battery from the bicycle.
-  Use both hands to remove the battery, taking special care not to drop it. Dropping the battery on your foot could cause injury and may damage the battery.

XPRO BATTERY

The Xpro additional battery or extender allows you to extend the bike's range. This is a bottle-shaped external 180 Wh battery that fits a specific bottle holder, which must be properly installed and connected to the system by an authorised store. When the bottle holder has been installed, the external battery is connected to the system by simply inserting it into the bottle holder. In other words, this is a Plug&Ride battery that requires no additional connection or work to operate.



CHARGING AND DISCHARGING THE XPRO BATTERY

The XPro battery will only be charged if it is in the XPro bottle holder, the bicycle is charging and iRemote is on. During the charging process, the internal battery will be charged first and then the external battery. The system will alternate between both batteries (cutting the power supply for 2-3 seconds when changing from one battery to another). In addition, to increase the service life of the batteries, the pedal assistance level will be limited as the battery runs out:

53%-127% Internal Available up to 100%	6%-13% Internal Available up to 25%
30%-53% Xpro Available up to 100%	4%-6% Internal Only lights available
23%-30% XPro Available up to 50%	3%-4% Internal No lights
13%-23% Internal Available up to 50%	

XPRO BOTTLE HOLDER

The bottle holder features a waterproof connector, guaranteeing the protection of the system. Therefore, the user can fit a conventional water bottle in the bottle holder or leave it empty.

ENERGY SAVING MODES

The battery has been designed to ensure a long service life. This is possible thanks to the energy saving modes that prevent inefficient battery consumption:

- **Transport mode:** In order to minimise internal consumption while transporting the bicycle from the factory to the store, the battery is in Transport mode. The user can finally exit this Transport mode by charging the battery to 100% before its first use.

If the battery does not charge fully, the Transport mode will not deactivate, repeatedly entering this mode quickly for its protection. Remember to fully charge the battery to finally deactivate the Transport mode.

- **Standby mode:** In order to minimise internal consumption, the battery automatically switches to Standby mode. This happens automatically when the system detects no charging, no discharging and no communication with the battery for a period of 10 minutes. So, for example, this mode will automatically turn off the control panel after 10 minutes without use, if the user has left it on after parking.

The user can exit this Standby mode by simply turning on the bicycle's control panel.

- **Deep Sleep mode:** In order to protect the battery during long periods of inactivity or storage (for example, during the winter), the battery automatically switches to Deep Sleep mode. This happens automatically when any of the following situations occur:
 - If the charge level of the battery is below 1%, the battery goes into Deep Sleep mode when the battery has continuously been in Standby mode for 10 minutes.
 - If the charge level of the battery is below 10%, the battery goes into Deep Sleep mode when the battery has continuously been in Standby mode for 48 hours.
 - If the charge level of the battery is below 40%: Deep Sleep mode is activated when the battery has continuously been in Standby mode for 14 days.
 - If the charge level of the battery is below 80%: Deep Sleep mode is activated when the battery has continuously been in Standby mode for 30 days.

The user can exit this Deep Sleep mode by pressing and holding the battery's SOC button (which checks the charge level) for 5 seconds or by starting to charge the battery with the charger. All LEDs will flash twice in the Standby mode and once in the Deep Sleep mode.

DISPLAY OF SECONDARY INFORMATION ON THE SCREEN

EC642 / EC622 / EC512 / EC502 / EC412 / EC312

The control panel's screen allows the user to view a range of useful information. The information on the screen changes when you press the POWER button according to the previous selection made in the "Settings" menu:

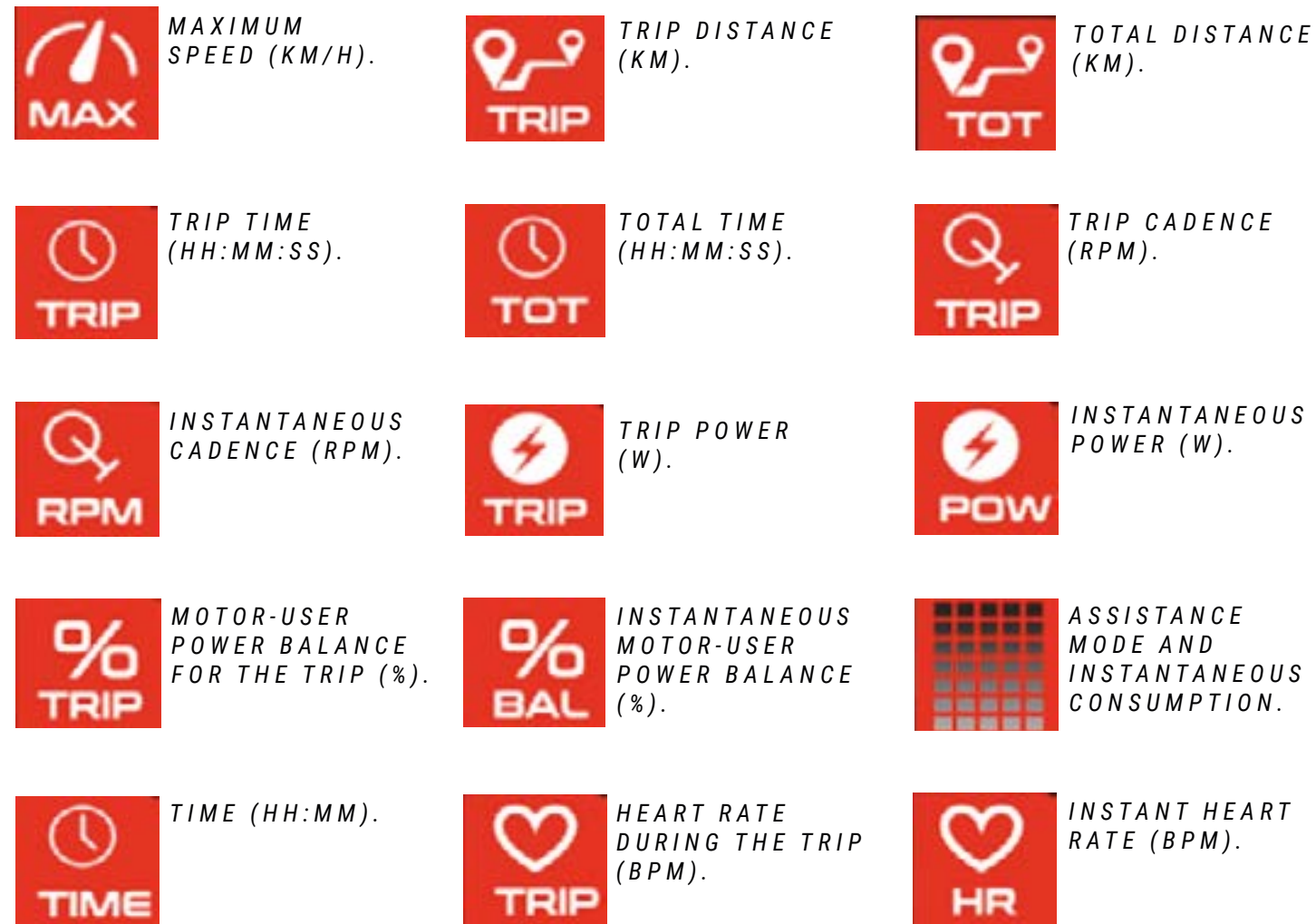
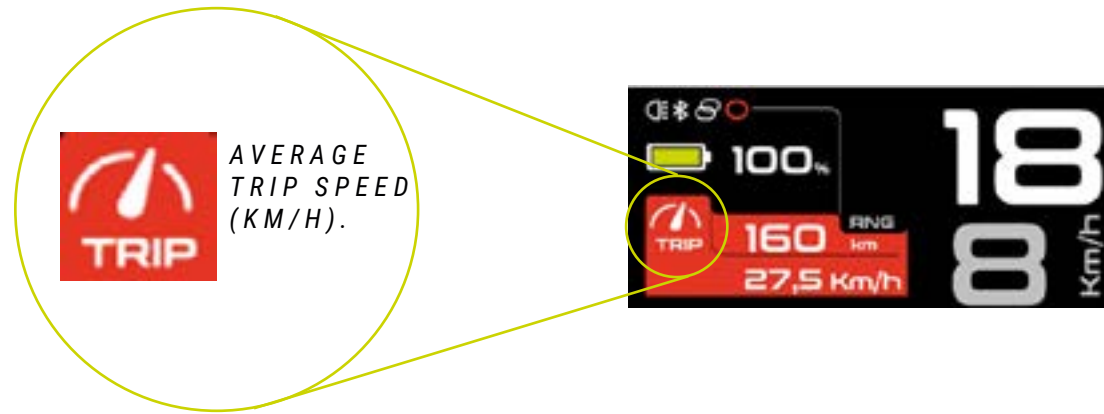

BATTERY CHARGE LEVEL INDICATOR

The battery charge level indicator shows the estimated remaining battery capacity.

In order to increase the life of the battery and prevent a full discharge which may damage it, the assistance modes are limited based on the state of charge of the battery:

- Battery charge above 20%: 100% of the highest assistance level is available.
- Battery charge between 10% and 20%: assistance level limited to 50% of the highest assistance level.
- Battery charge between 5% and 10%: assistance level limited to 25% of the highest assistance level.
- Battery charge between 1% and 5%: assistance is not permitted. Only the lights can be turned on.

SETTINGS MENU

The user can access the settings menu by pressing and holding the (+) and (-) buttons for 3 seconds. Press the (+) and (-) buttons to scroll through the different settings options. When you press the POWER button, you will enter the selected menu. Additionally, the system will exit the settings menu when the user presses and holds the POWER button for 3 seconds.

- ⚠ When making any adjustments, make sure that you stop the bicycle and perform them in a safe place. Otherwise, the lack of attention to the surrounding traffic could cause a fatal accident.



Resetting the trip information.

The user can view and reset the trip information at any time.



Selecting Secondary information on the Screen.

The user can select the information that will be shown on the screen's secondary information indicator.



Start-up profile.

The user can select the system start-up settings. Every time that the user turns the control panel on and off, the system will change the settings to those selected in this menu:

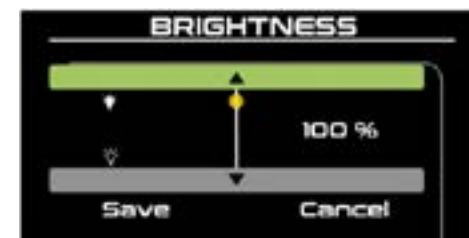

Screen brightness selection.

The user can alter the brightness of the screen so that they can view it correctly.



Metric and Imperial systems.

The user can switch between the metric system (kilometres) and imperial system (miles).



Condition of the battery.

Via this menu, the user can view the battery's state of deterioration.

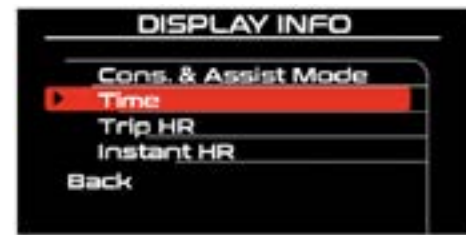
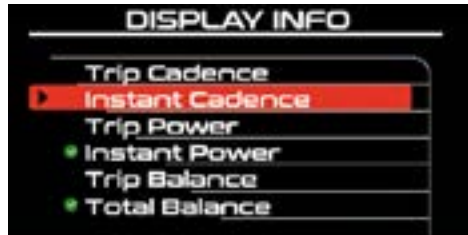

Secondary information.

The battery is a consumable that degrades over time and with use, gradually losing its energy storage capacity. The state of deterioration of the battery (State of Health) offers information about the speed of the battery deterioration based on the following colour criteria:

The battery is a consumable that degrades over time and with use, gradually losing its energy storage capacity. The state of deterioration of the battery (State of Health) offers information about the speed of the battery deterioration based on the following colour criteria:

- **Green:** Low deterioration level.
- **Orange:** Moderate deterioration level.
- **Red:** High deterioration level.



Secondary information.



Lighting system.

This operates according to the control panel's lighting level sensor.



Resetting trip information.

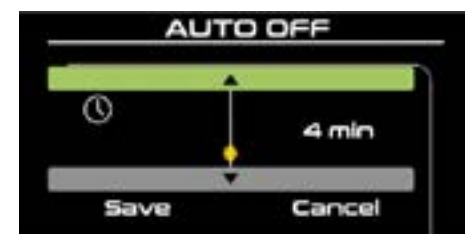

Auto power-off.

Sets the display's auto power-off time.



Smart key / Security Smart key.

Activates or deactivates the security function.

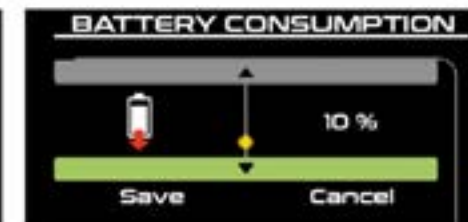
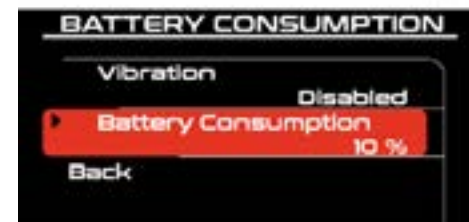
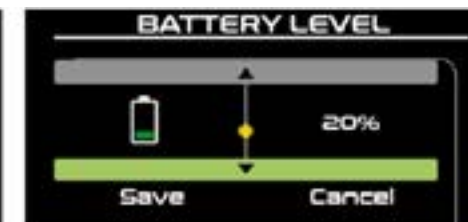
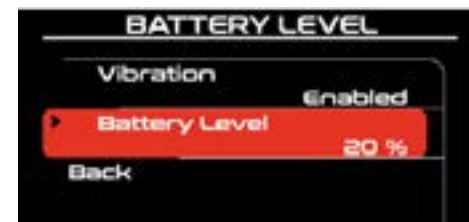



Motor settings.

Via this menu, the user can manage the motor's performance for each assistance mode.

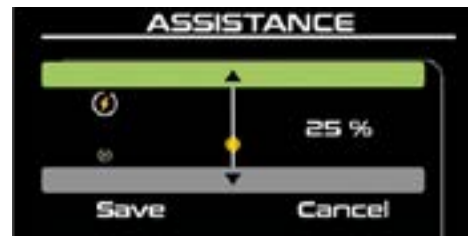

Assistance level by mode.

This is the minimum (1%) and maximum (100%) percentage level of assistance offered by the motor.

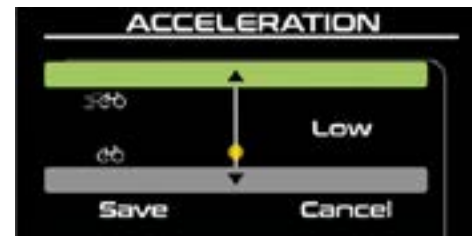

Acceleration.

There are 3 levels (Low, Medium, High) that represent the level of acceleration when starting up the motor.

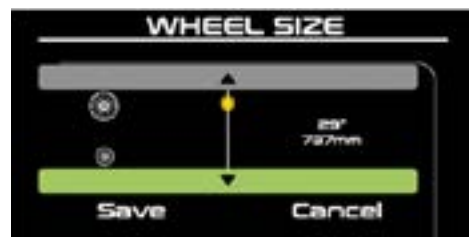

Wheel Size Selection.

The user can change the wheel size at any time.



Language selection.

The user can change the screen language.

NOTIFICATIONS

The notifications can also be managed in the setup menu. This model has the following notifications:

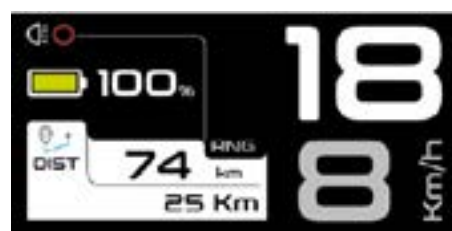

Distance.

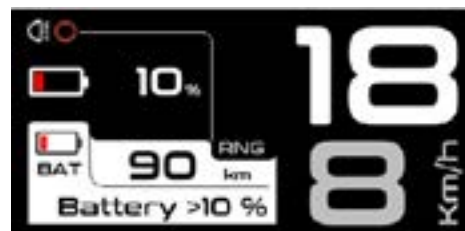

Battery level.

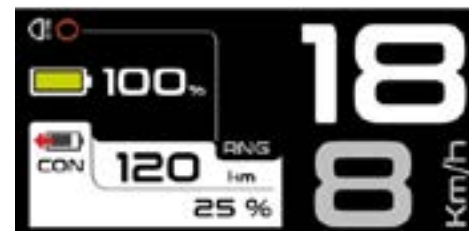

Battery consumption.



Nutrition reminder.



Hydration reminder.



Maintenance reminder.

BLUETOOTH ANT+

The user can manage the Bluetooth connection with their smartphone and Ant+ with compatible devices using the control panel for additional functions.



APP BH BIKES ICONNECT

The BH Bikes iConnect app can be used to customise the configuration of the pedal assistance system:

- Change the assistance level colours.
- Changing the assistance (0-100%) and acceleration parameters for each level of assistance.

Download the app (available for IOS and Android) and follow these steps to link your bicycle to the app:

App Store: <https://apps.apple.com/es/app/bh-bikes-icconnect/id1494346206>



Google Play: <https://play.google.com/store/apps/details?id=com.bh.ebikelight>



Watch the video from the following link to learn how the app works:

<https://youtu.be/k4sOiG0cX3U>



The general operation is described below:

1. TAP ON "SEARCH" TO SEARCH FOR AVAILABLE DEVICES.



2. TAP ON UPLOAD TO LOAD THE BICYCLE'S CONFIGURATION TO THE APP.

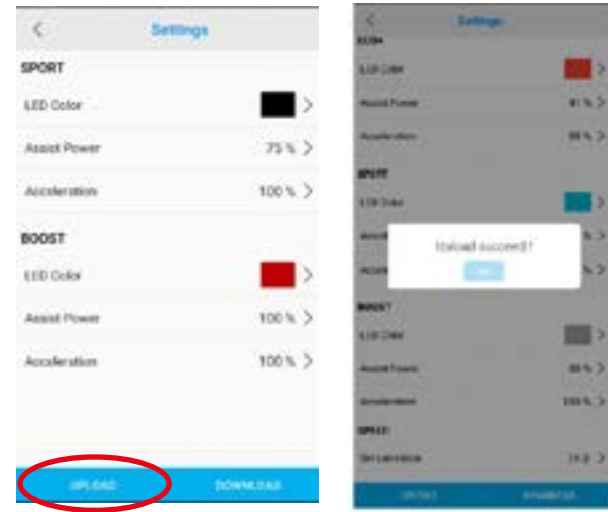

3. CHANGE THE COLOUR, ASSISTANCE AND ACCELERATION OF EACH MODE.



4. TAP ON "DOWNLOAD" TO SEND THE DATA TO THE BICYCLE.



OPERATION WITH THE GARMIN DEVICE

The ANT+ connection to a Garmin device grants you access to additional assistance display and control functions. The Heart Rate strap connects via the Garmin device. The steps that must be followed to connect iRemote to the Garmin device are described below. The image in the sixth step shows that the Garmin device can be used to check the bicycle's battery status and to select the desired pedal assistance level.

1. TAP ON "ADD SENSOR".

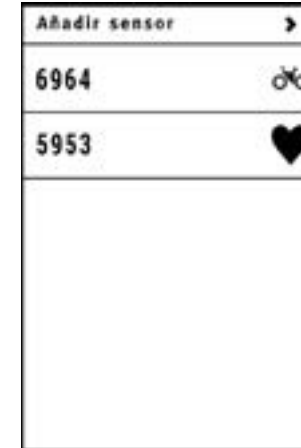

2. TAP ON "E-BIKE".

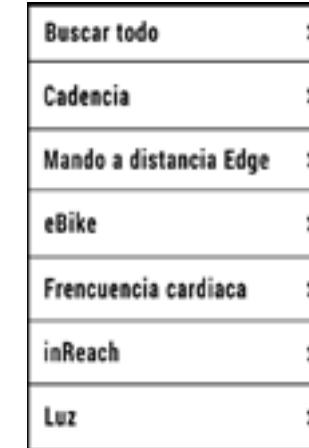

3. PAIR WITH YOUR GARMIN DEVICE.



4. SELECT THE E-BIKE.

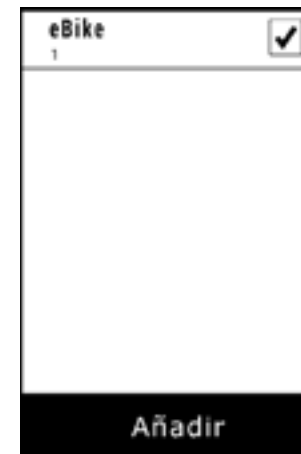

5. SELECT THE SENSOR YOU HAVE CREATED.

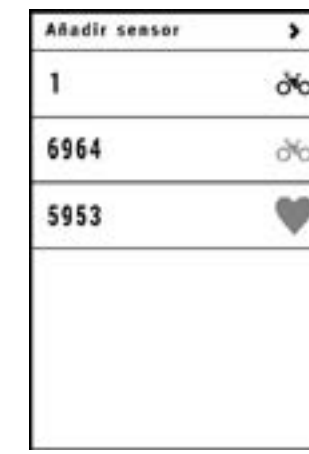

6. GARMIN CONNECTED.



SOFTWARE UPDATE OF THE I-REMOTE

[EC642](#) / [EC622](#) / [EC512](#) / [EC502](#) / [EC412](#) / [EC312](#)

The BH control panel and display software must be up-to-date at all times. Updates optimise the safety, energy efficiency, reliability and overall operation of the electrical system. Updates are published on a regular basis on the BH Bikes website. You can find them at the path About / Downloads and manuals / Display updates or at the following link:

https://www.bhbikes.com/es_INT/quienes-somos/manuales-descargas

The latest updates should be checked and the necessary actions should be carried out during regular maintenance or repairs at an official dealer.

⚠ Keep in mind that some actions require advanced knowledge and incorrect handling may cause serious accidents. In addition, incorrect handling will not be covered by the warranty.

Watch the video by clicking on the link below to learn about the entire update process:

<https://youtu.be/FDeiQiV1Aow>



ERROR CODES

Errors will be shown on the display. Below are the errors and the actions that must be taken, both on the Core display and the X-Display.

[EC282](#) / [EC262](#) / [EC182](#) / [EC162](#) / [EC242](#) / [EC222](#) / [EC142](#) / [EC122](#)

The errors will be shown with the LEDs in models equipped with the Core display. The number of LEDs that are on or off will refer to a specific error. Below is a description of the possible problems:



ERROR DESCRIPTION

Nº	Code	Description	Action required
0		System Normal	
1		Overcurrent (excessive current)	Please check if the connector between the motor and controller is loose. If not, install a new controller!
2		Static current over limit	Please change the controller
3		Throttle or TMM Signal Abnormal	Please check if the connector between the TMM sensor and controller is loose. Please check if the output of the TMM sensor exceeds the normal range, it should be 0.1V-3.5V.
4		Incorrect motor phase	Please check the motor connector or controller.

ERROR DESCRIPTIONS

N°	Code	Description	Action required
5		Motor Hall sensor error	Please check if the connector between the motor and controller is loose. Hall sensor inside of the motor is broken, replace the Hall sensor or install a new motor. Bad contact of the controller-motor cable, install a new controller.
8		Low Battery voltage	Change the battery or check the battery output
9		Motor stalled	Motor stops by accident; motor stalled.
10		Current over limit	Bad contact of the controller-motor connector if needed, install a new one.
11		Motor overheating alarm	If the temperature exceeds the setting, the current will start to gradually decrease
12		Motor overheating protection	Entering the temperature protection mode, no controller output
13		Communication error	1. Communication line was loose, please check the communication cable and its connector 2. The Controller's MCU is malfunctioning, change the controller. 3. Short in the TMM wire, please disconnect the TMM sensor to check it. 4. Short in the motor Hall wires, please disconnect the motor connector and check again, 5. The motor power wires touched the Hall wires, causing damage and shorting the Hall wires. 6. Display communication parts malfunctioning, please install a new display. 7. Check the Display and CAN controller Communication line was loose (REVO ONLY)
14		Foot error	Please remove your feet from the pedals and switch on again.
33		Fault_e_SpeedSensorNoInts	Switch the system off completely and then back on. If the problem persists, contact your e-bike dealer.

EC642 / EC622 / EC512 / EC502 / EC412 / EC312

The errors will be shown with the LEDs in models equipped with the X-Display. In some cases, the steps required to try and resolve the error will be included in the error notification.

The possible errors and the actions to be taken are shown below:



ERROR DESCRIPTIONS

Code	Description	Action required
1	Remote abnormal signal.	RESTART THE SYSTEM.
2	Remote communication.	MAKE SURE THAT THE DISPLAY CONNECTOR 15 IS PLUGGED IN CORRECTLY.
3	Torque sensor.	RESTART THE SYSTEM.
4	Battery undervoltage.	FULLY CHARGE THE BATTERY WITH THE ORIGINAL CHARGER. RESTART THE SYSTEM.
5	Battery undervoltage.	RESTART THE SYSTEM.
6	Motor Hall sensor.	RESTART THE SYSTEM.
7	Motor overheating.	STOP RIDING AND WAIT UNTIL THE MOTOR COOLS DOWN.
8	Drive unit sensor overtemperature.	RESTART THE SYSTEM.
9	Drive unit current out of range.	RESTART THE SYSTEM.
11	Communication.	MAKE SURE THAT THE DISPLAY CONNECTOR IS PLUGGED IN CORRECTLY. RESTART THE SYSTEM.

ERROR DESCRIPTIONS

Code	Description	Action required
12	Battery discharged.	FULLY CHARGE THE BATTERY WITH THE ORIGINAL CHARGER. RESTART THE SYSTEM.
14	Drive unit overcurrent.	REDUCE THE LOAD ON THE MOTOR BY PEDALLING LESS OR BY REDUCING THE ASSISTANCE LEVEL. RESTART THE SYSTEM.
24	Drive unit power.	RESTART THE SYSTEM.
25	Drive unit serial number not detected	RESTART THE SYSTEM.
26	Drive unit reset cause.	RESTART THE SYSTEM.
33	Speed sensor.	CHECK SPEED SENSOR AND MAGNET POSITION IN THE WHEEL.
34	Drive unit overvoltage.	RESTART THE SYSTEM.
35	Cadence sensor.	RESTART THE SYSTEM.
36	Lights low voltage.	CHECK LIGHT CABLES AND POTENTIAL SHORT.
193	Cell over voltage.	FULLY DISCHARGE THE BATTERY. FULLY CHARGE THE BATTERY WITH THE ORIGINAL CHARGER. ONCE FULLY CHARGED, KEEP THE CHARGER PLUGGED IN FOR 2 HOURS TO BALANCE THE CELLS. RESTART THE SYSTEM.
194	Cell undervoltage.	FULLY DISCHARGE THE BATTERY. FULLY CHARGE THE BATTERY WITH THE ORIGINAL CHARGER. ONCE FULLY CHARGED, KEEP THE CHARGER PLUGGED IN FOR 2 HOURS TO BALANCE THE CELLS. RESTART THE SYSTEM.
197	Overcurrent charge.	CHECK THE STATUS OF THE ORIGINAL CHARGER. RESTART THE SYSTEM.
198	Overcurrent discharge.	RESTART THE SYSTEM.
199	Short circuit.	CHECK CHARGER CABLE STATUS. RESTART THE SYSTEM.
204	Temperature charging.	STOP CHARGING FOR 30 MINUTES. RESTART THE SYSTEM.
205	Temperature discharging.	RESTART THE SYSTEM.

07 SIZES AND DIMENSIONS

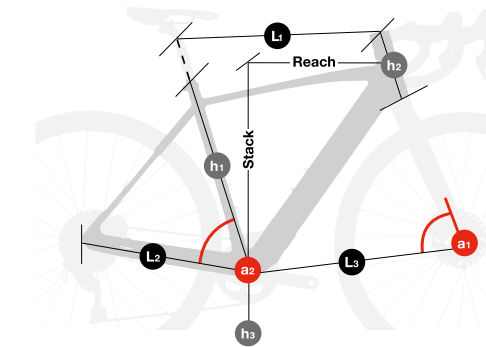

EC282 EC262 CORE GRAVELX CARBON

	h1	h2	L1	L2	L3	a1	a2	Stack	Reach
SM	450	145	538	420	592	70,8	73,8	544	379
MD	470	160	558	420	597	72,3	72,8	562	389
LA	500	170	578	420	608	72,8	72,8	578	399

EC182 EC162 CORE RACE CARBON

	h1	h2	L1	L2	L3	a1	a2	Stack	Reach
SM	450	145	540	420	591	71,0	74,0	542	381
MD	470	160	560	420	596	72,5	73,0	560	391
LA	500	170	580	420	607	73,0	73,0	576	401

EC642 EC622 CORE PRO CORE 29

	h1	h2	h3	L1	L2	L3	a1	a2	Stack	Reach
SM	400	110	313	587	470	675	69,0	74,0	625	408
MD	450	120	313	604	470	692	69,0	74,0	34	422
LA	500	130	313	629	470	24	69,0	74,0	43	444

EC512 CORE JET

	h1	h2	h3	L1	L2	L3	a1	a2	Stack	Reach
SM	400	140	290	581	455	666	70	74,3	557	425
MD	440	150	320	592	455	680	70	74,0	537	438
LA	480	160	319	606	455	695	70	74,0	546	449

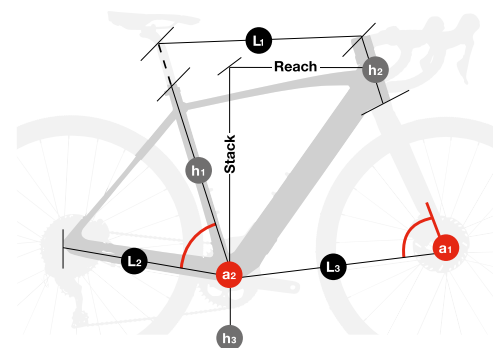

08 TECHNICAL SPECIFICATIONS

GENERAL SPECIFICATIONS

Characteristics	Models	Specification
Frame materials	EC642 / EC622 / EC512 / EC502 / EC412 / EC312 / EC242 / EC222 / EC142 / EC122	Aluminium
	EC282 / EC262 / EC182 / EC162	Carbon
Recommended use	EC282 / EC262 / EC242 / EC222	Gravel
	EC182 / EC162 / EC142 / EC122	Road
	EC642 / EC622 /	Sport
Sizes	EC512 / EC502 / EC412 / EC312 /	Hybrid/Urban
	All	See section "07 Sizes and dimensions"
Suspension design	EC642 / EC622 / EC412 / EC312	Front suspension.
	EC282 / EC262 / EC182 / EC162 / EC512 / EC502 / EC242 / EC222 / EC142 / EC122	No suspension.
Fork travel	EC642 / EC622	100mm
	EC412 / EC312	63mm
Maximum fork length (axle to crown)	All	Depends on the bicycle model.
Fork offset	All	Contact the model's supplier.
Steering	All	Depends on the model.
Chain line	All	Depends on the model.
Steering	All	Varies according to the model.

EC502 CORE CROSS

	h1	h2	h3	L1	L2	L3	a1	a2	Stack	Reach
SM	450	150	290	594	455	673	71	74,6	571	437
MD	500	160	290	604	455	677	71	74,0	580	438
LA	550	170	289	637	455	705	71	73,5	590	463

EC412 CORE CITY WAVE

	h1	h2	h3	L1	L2	L3	a1	a2	Stack	Reach
MD	480	150	291	600	455	685	70	75,0	643	428
LA	540	160	286	630	455	715	70	75,0	652	454

EC312 CORE STREET

	h1	h2	h3	L1	L2	L3	a1	a2	Stack	Reach
MD	410	150	283	607	433	680	71	74,9	600	445

EC242 EC222 CORE GRAVELX 2.4 / 2.2

	h1	h2	h3	L1	L2	L3	a1	a2	Stack	Reach
SM	520	120	280	547	428	603	71	73,3	551	381
MD	540	140	280	562	428	605	72	73,0	574	386
LA	560	160	280	582	428	623	72	72,8	593	398

EC142 EC122 CORE RACE 1.4 / 1.2

	h1	h2	h3	L1	L2	L3	a1	a2	Stack	Reach
SM	470	145	270	545	420	594	72	74,0	544	388
MD	490	160	270	562	420	597	73	73,0	561	391
LA	510	175	270	583	420	607	73	72,5	577	401

GENERAL SPECIFICATIONS

Characteristics	Models	Specification
Chain line	All	Varies according to the model.
Wheel size	EC642 / EC622	29"
	EC282 / EC262 / EC182 / EC162 / EC512 / EC502 / EC412 / EC242 / EC222 / EC142 / EC122	28"
	EC312	26"
Maximum size of the rear tyre	All	2.4" (61mm)
Maximum size of the front tyre	All	Depends on the type of fork.
Speed magnet assembly	All	On the rear wheel spokes.
Standard rear axle	All	Varies according to the model.
Rear axle pitch thread	All	1 mm
Length of the rear axle	All	Varies according to the model.
Seat post diameter	EC642 / EC622 / EC512 / EC502 / EC412 / EC312	31.6mm
	EC242 / EC222 / EC142 / EC122	27.2mm
Seat post clamp diameter	EC282 / EC262 / EC182 / EC162	Built-in
Maximum insertion length of the seat post	EC642 / EC622 / EC512 / EC502 / EC412 / EC312	35mm
	EC242 / EC222 / EC142 / EC122	31.8
S	All	200mm
M	All	220mm
L	All	240mm

Characteristics	Models	Specification
XL	All	240mm
Compatible with a telescopic seat post with internal cabling	All	Yes
Front derailleur	All	No. Only 1X
Maximum chain ring size	All	38t
Minimum chain ring size	All	30t
Compatible with the oval chain ring	All	No
Type of brakes	All	Disc brakes
Standard rear brake calliper	All	Post Mount
Maximum rear disc size	All	203mm
Minimum rear disc size	All	180mm
Compatible with chain guides	All	Yes
ICGS	All	No
Cabling	All	Internal through DT and CS. Full housing
Compatible with left rear brake cabling	All	Yes
Compatible with bottle holder	EC282 / EC262 / EC182 / EC162 / EC642 / EC622 / EC242 / EC222 / EC142 / EC122	Yes
Potentiometer compatibility	All	No
Compatible with trailers	All	No
Pannier rack assembly	EC512 / EC502 / EC412 / EC312	Yes
Mudguard assembly	EC512 / EC502 / EC412 / EC312	Yes
Child seat assembly	EC512 / EC502 / EC412 / EC312	Yes
Maximum recommended weight (cyclist+equipment+bags)	All	165Kg

BH-2EXMAG MOTOR SPECIFICATIONS

Characteristics	Specification
Rated power	250W
Voltage	36V
Type	Brushless DC
Assistance	Hasta 25km/h
Maximum torque	65Nm
Weight	2100g
Pedal assistance modes	6
Walk assist	Yes (by pressing and holding the + button)
Cadence range	130/min.
Sensors	Cadence / Torque / Speed
System technology	CAN bus

BATTERY SPECIFICATIONS

Characteristics	Specification
Voltage	36V
Capacity	EC282 / EC642 : 540WH+180WH All other models: 540 WH
Weight	540WH: 2200g y 180WH: 1000g
Cell pack	540+180WH: (10S3P+10S1P) y 540WH: 30 (10S3P)
Charge level	With battery inside the frame.
Dimensions	462x67x49mm
Connection	Cable connected to the motor and charging port.
Watertightness	IP65

CHARGER SPECIFICATIONS

Characteristics	Specification
Input	100-240V. 50-60Hz. AC
Output	42V
Charging current	4A
Charging temperature range	0°C - 40°C
Display of the charging progress	With the LED built into the charger

EC642 / EC622 / EC512 / EC502 / EC412 / EC312

SPECIFICATIONS OF THE X-REMOTE CONTROL PANEL

Characteristics	Specification
Functions	Change of assistance mode. / On and off.

EC642 / EC622 / EC512 / EC502 / EC412 / EC312

SPECIFICATIONS OF THE X-DISPLAY

Characteristics	Specification
Functions	Display of the charge level. / Display of errors. / Display of the selected assistance mode. / Display of the trip information.

EC282 / EC262 / EC182 / EC162 / EC242 / EC222 / EC142 / EC122

SPECIFICATIONS OF THE BH CORE CONTROL PANEL/DISPLAY

Characteristics	Specification
Functions	Change of assistance mode. / On and off. / Display of the charge level. / Display of errors.

SPEED SENSOR SPECIFICATIONS

Characteristics	Specification
Assembly	On the left chainstay. Outer cabling.
Magnet	On the rear wheel spokes.

09 ASSEMBLY AND SPARE PARTS

DIMENSIONS OF THE STEERING TUBE

EC282 / EC262 / EC182 /
EC162 / EC242 / EC222 /
EC142 / EC122

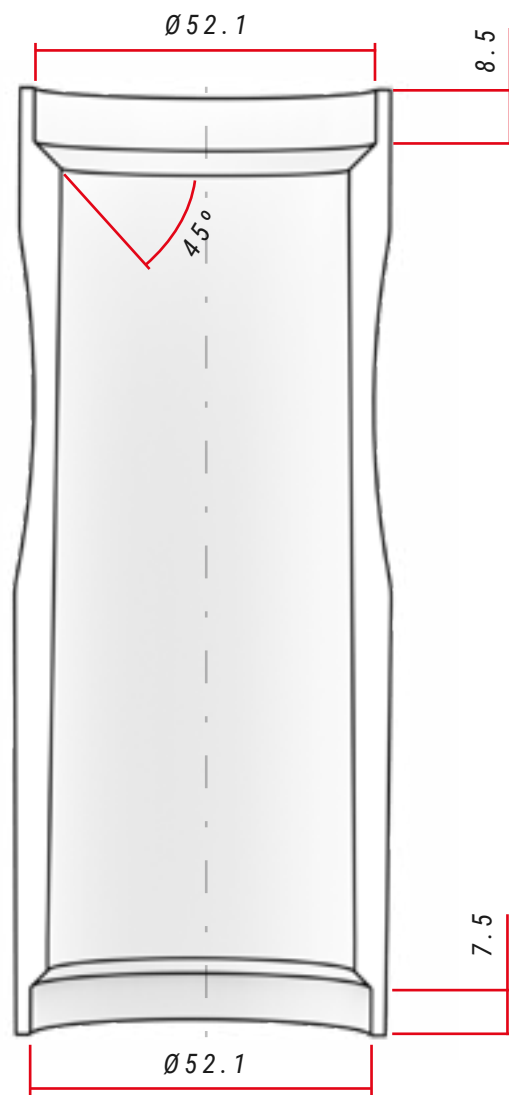

EC642 / EC622

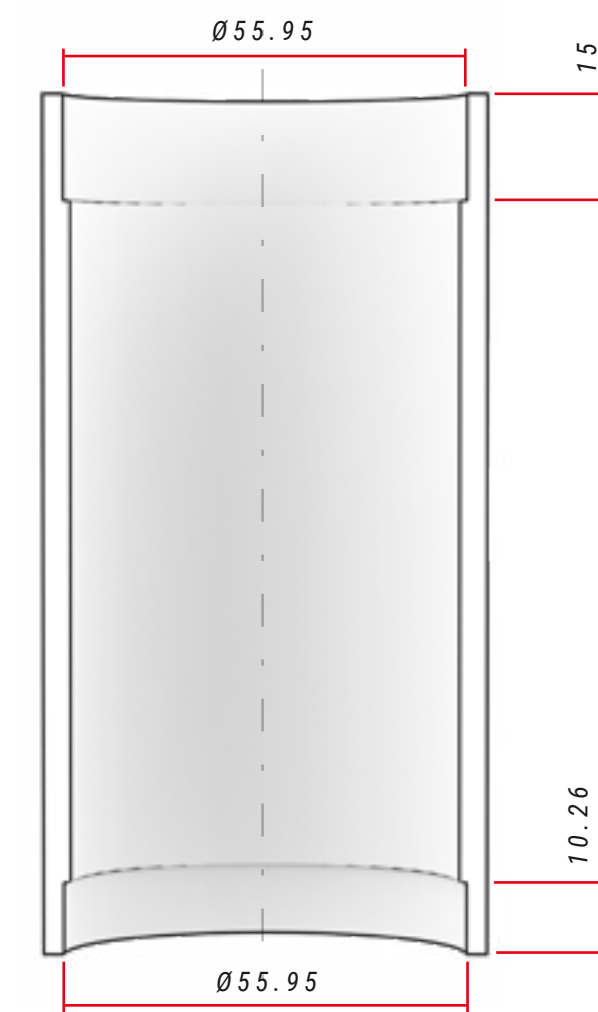

STEERING SPECIFICATIONS

Type	Contact angle with the compression ring / fork track	Bearing dimensions
Upper	1 1/8" Steerer	45°
Lower	1,5" Steerer	45°

STEERING SPECIFICATIONS

Type	Contact angle with the compression ring / fork track	Bearing dimensions
Upper	Depends on the model	Depends on the model
Lower	Depends on the model	Depends on the model

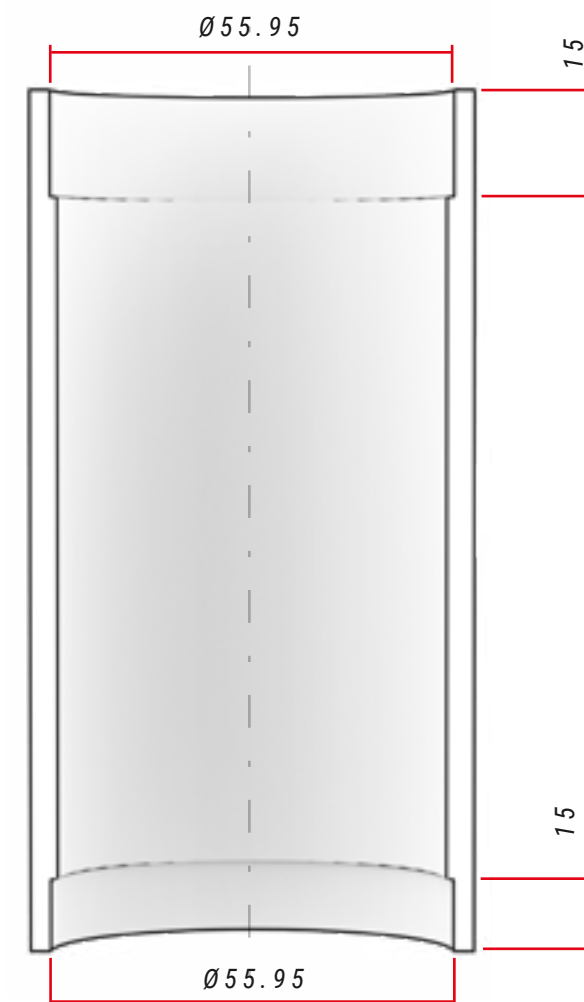
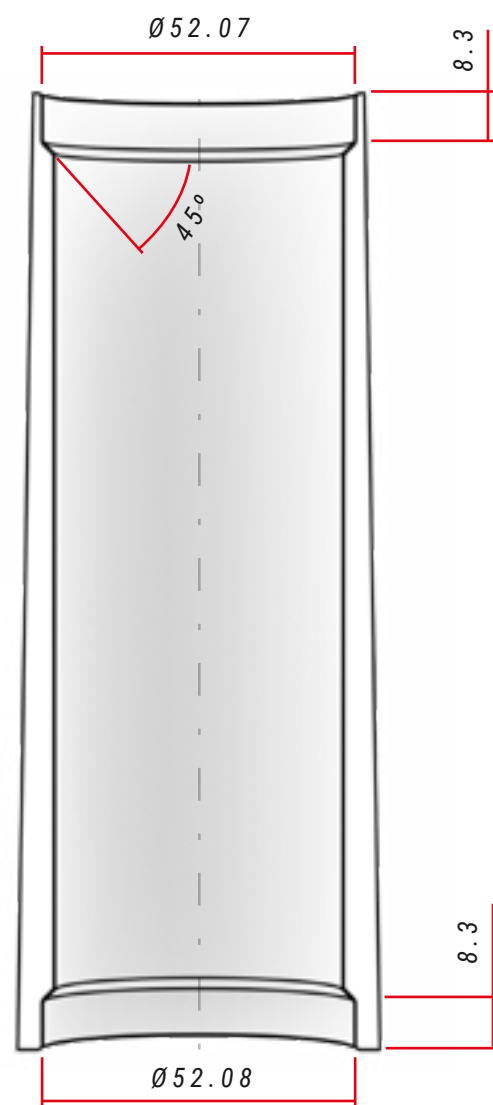

STEERING SPECIFICATIONS

Type	Contact angle with the compression ring / fork track	Bearing dimensions
Upper	Depends on the model	Depends on the model
Lower	Depends on the model	Depends on the model

STEERING SPECIFICATIONS

Type	Contact angle with the compression ring / fork track	Bearing dimensions
Upper	Depends on the model	Depends on the model
Lower	Depends on the model	Depends on the model

BH LITE AHEAD / AERO ACR STEM

EC182

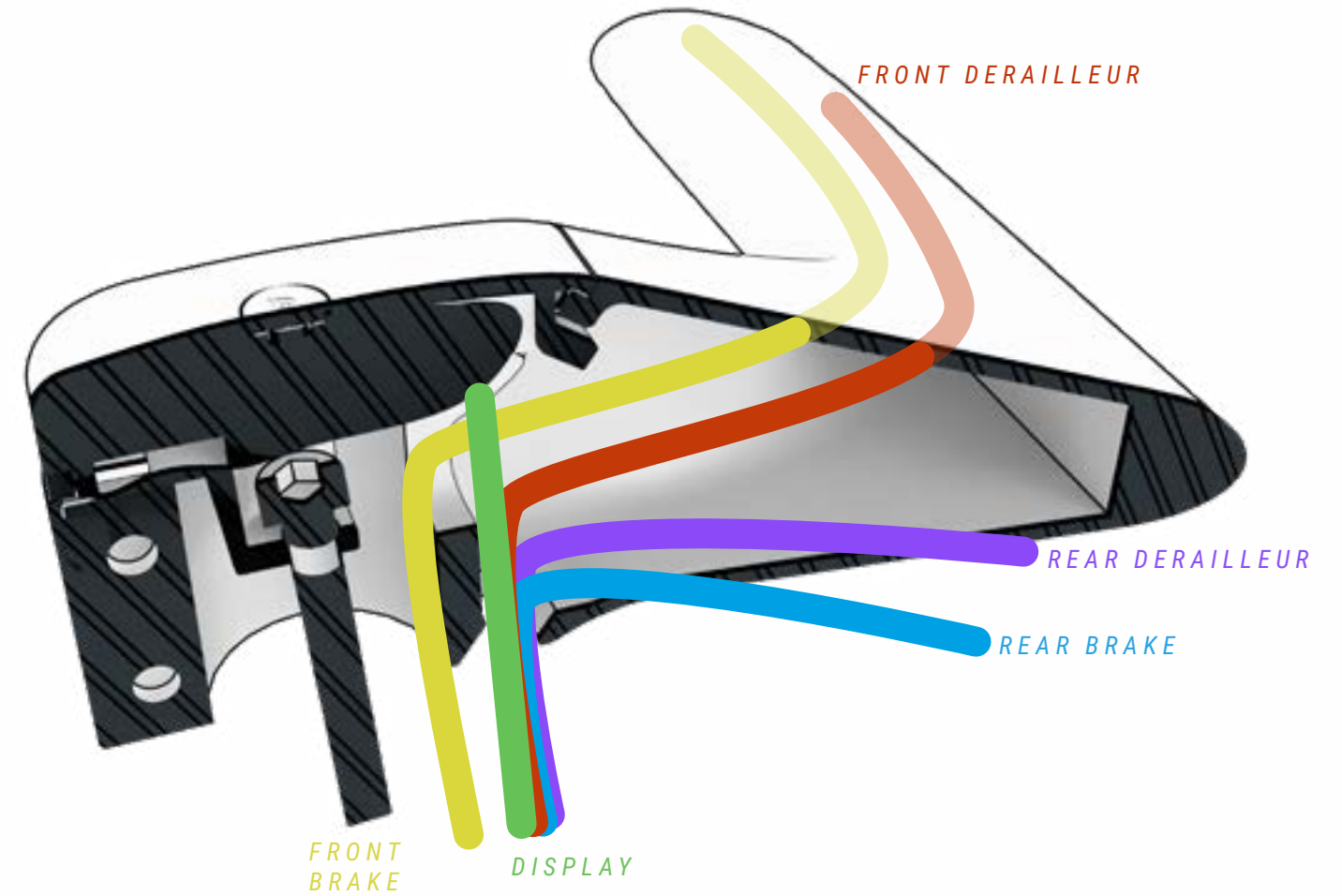
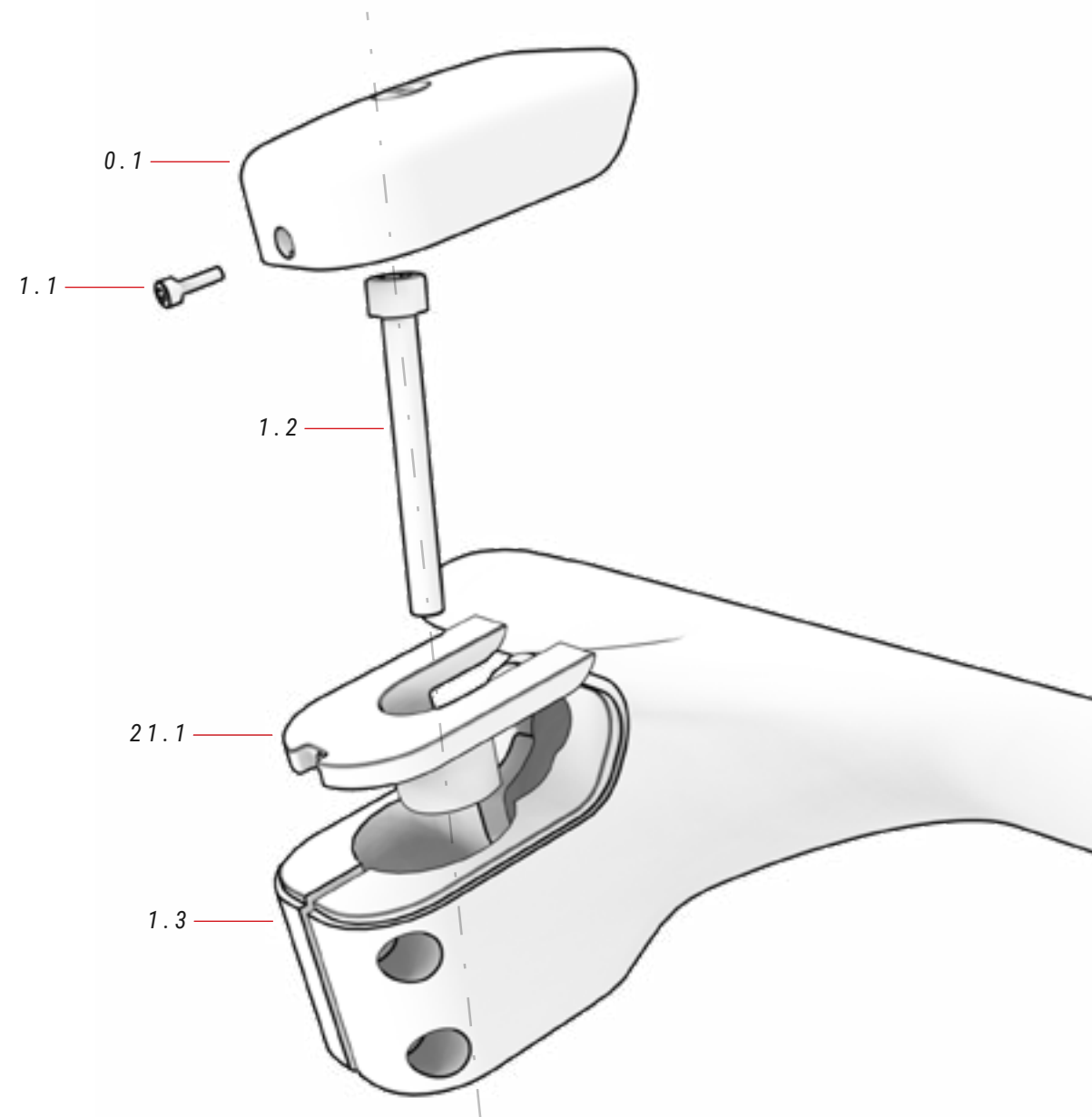

00 CORE DISPLAY ref.: 386129900

No.	Item	Quantity
0.1	CORE display	1

21 DISPLAY HOLDER ref.: 384632900

No.	Item	Quantity
21.1	Display holder	1

01 BH AERO ACR STEM ref.: 391731400

No.	Item	Quantity
1.1	Display bolt	1
1.2	Bolt	1
1.3	Stem	1

BH LITE AHEAD / AERO ACR STEM

EC282 / EC262 / EC242 / EC222

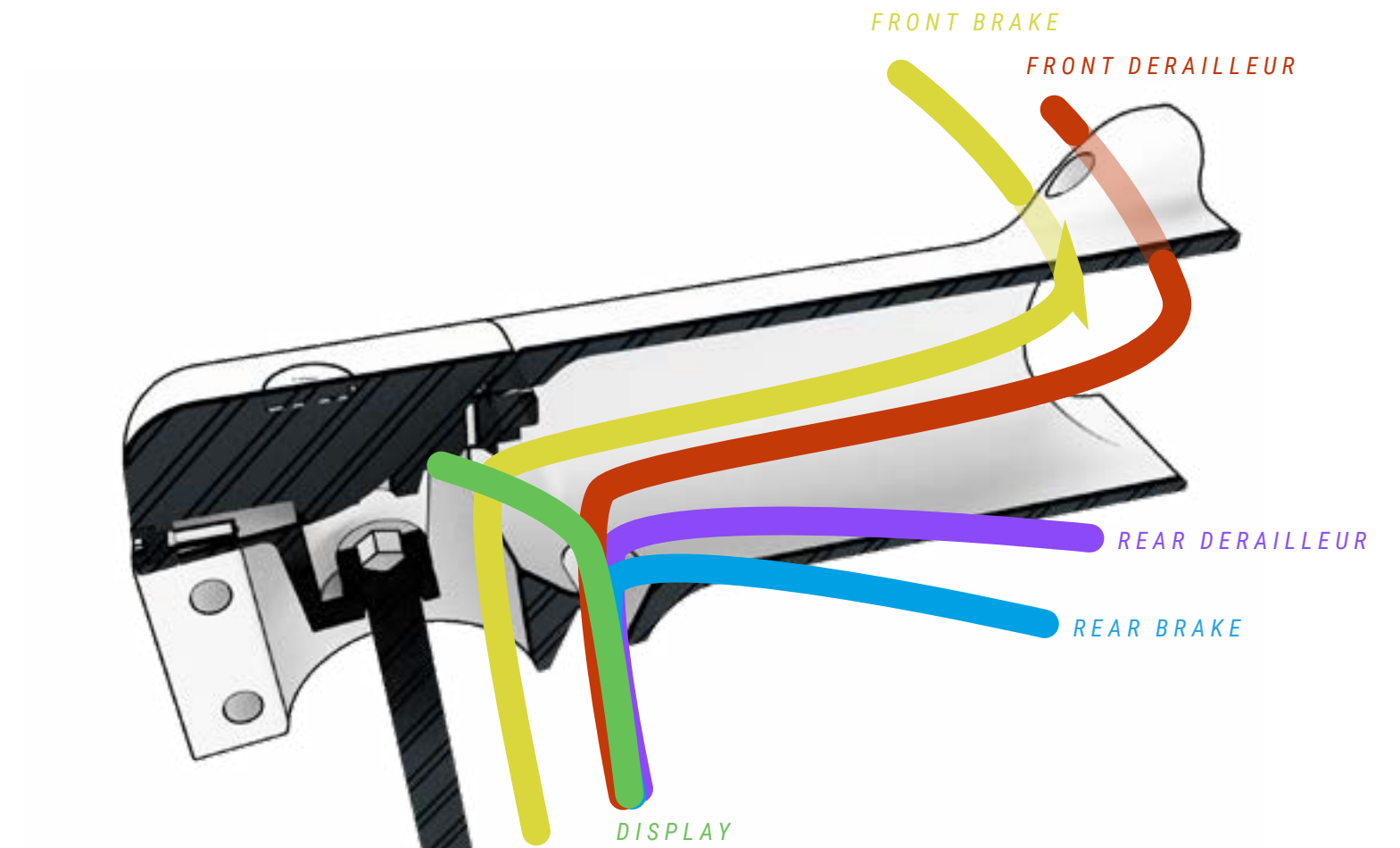
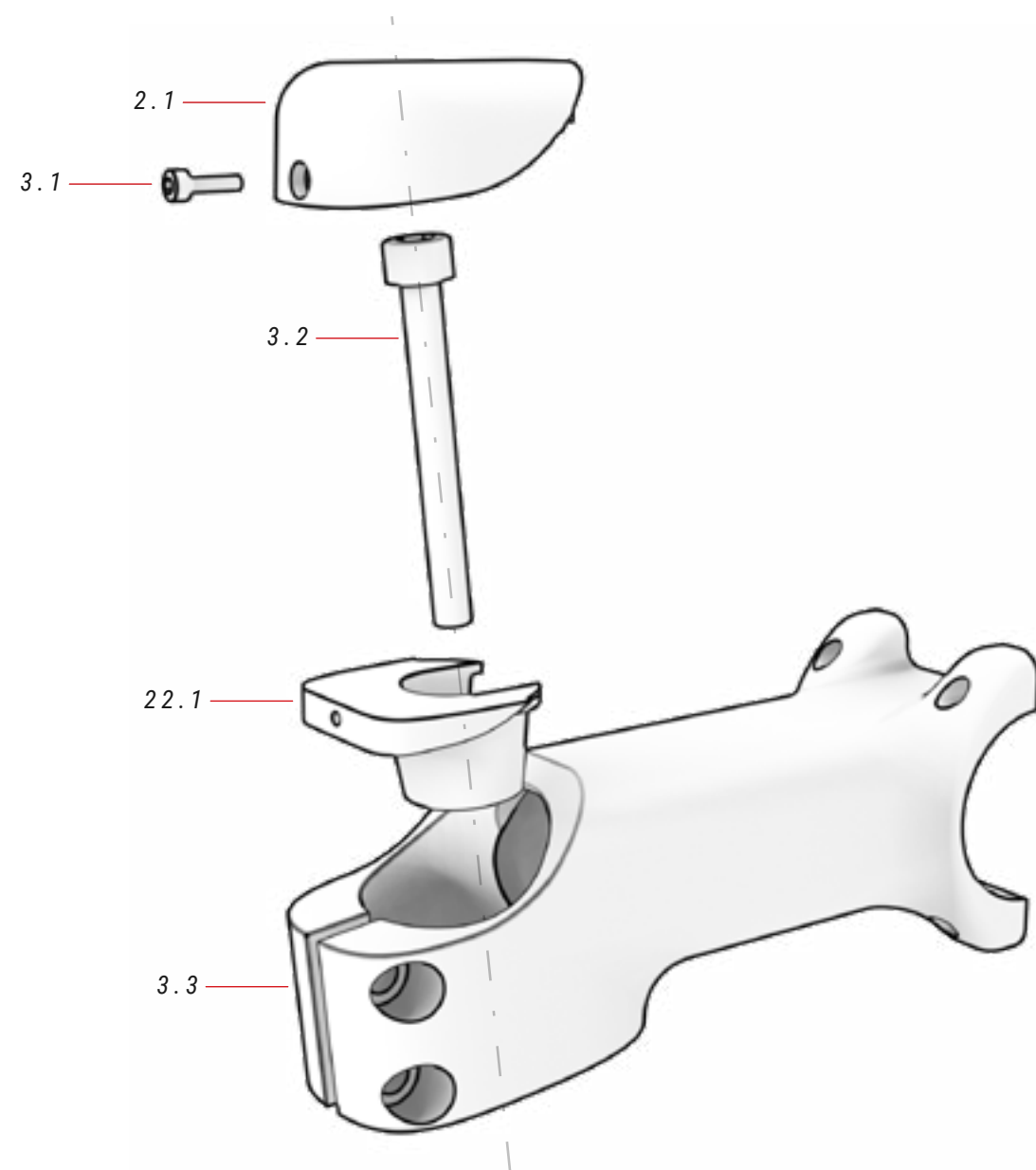

02 DISPLAY CORE ref.: 386129900

No.	Item	Quantity
2.1	Display CORE	1

22 DISPLAY HOLDER ref.: 384625000

No.	Item	Quantity
22.1	Display holder	1

03 FSA ACR STEM

No.	Item	Quantity
3.1	Display bolt	1
3.2	Bolt	1
3.3	Stem	1

HEADSET

EC282 / EC262 / EC182 / EC162 / EC242 / EC222 / EC142 / EC122

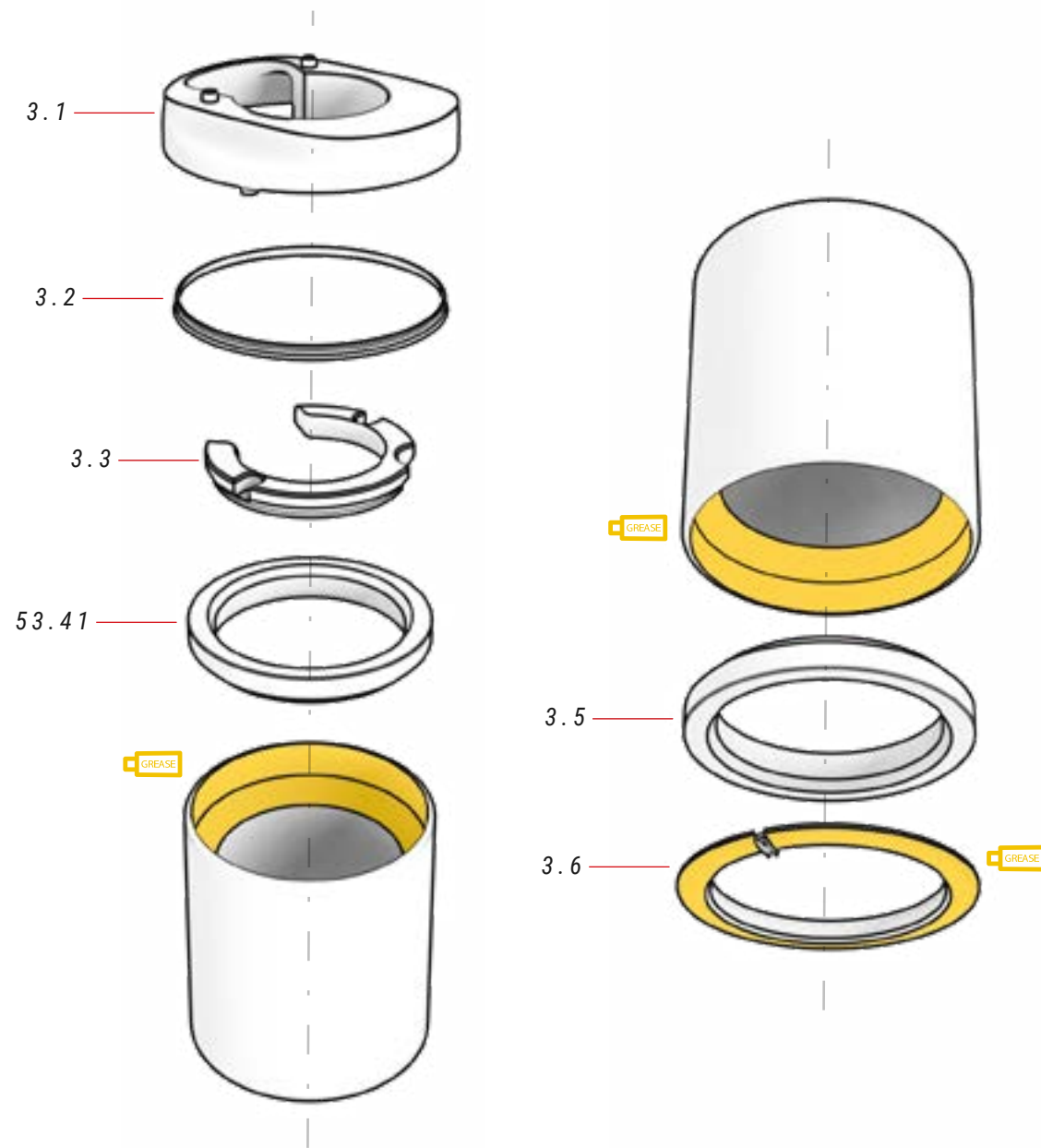

04 HEADSET

No.	Item	Quantity
3.1	Headset cover	1
3.2	Washer	1
3.3	Cable duct	1

No.	Item	Quantity
3.4	Bearing	1
3.5	Bearing	1
3.6	Lower cover	1

BUILT-IN BH SEAT POST CLAMP

EC282 / EC262 / EC182 / EC162

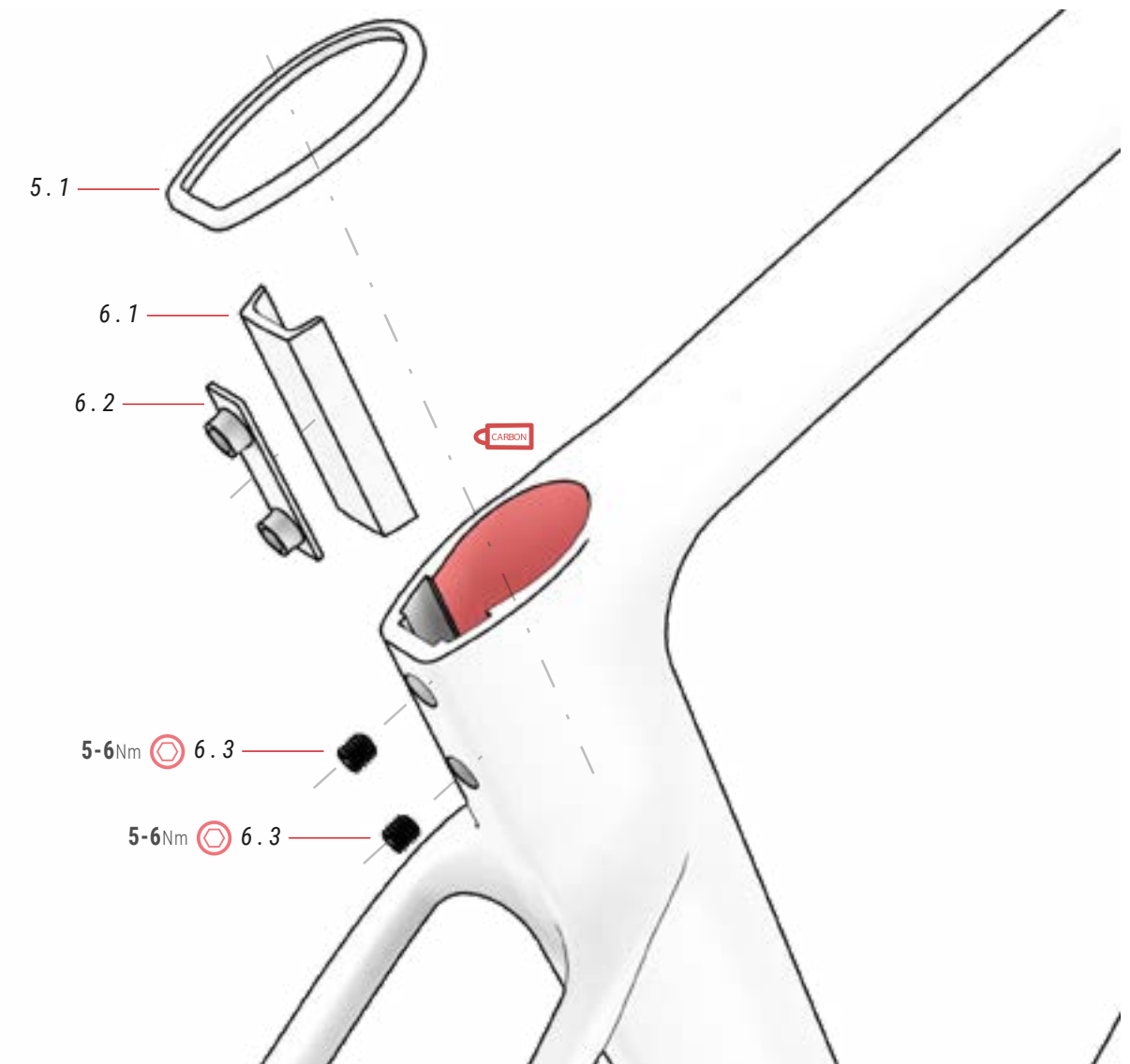

05 CLAMP COVER

ref.: 384669500

No.	Item	Quantity
5.1	Clamp cover	1

06 SADDLE CLAMP

ref.: 384669400

No.	Item	Quantity
6.1	Plate	1
6.2	Fastening plate	1
6.3	Stay bolt	2

HANGER

EC282 / EC262 / EC182 / EC162

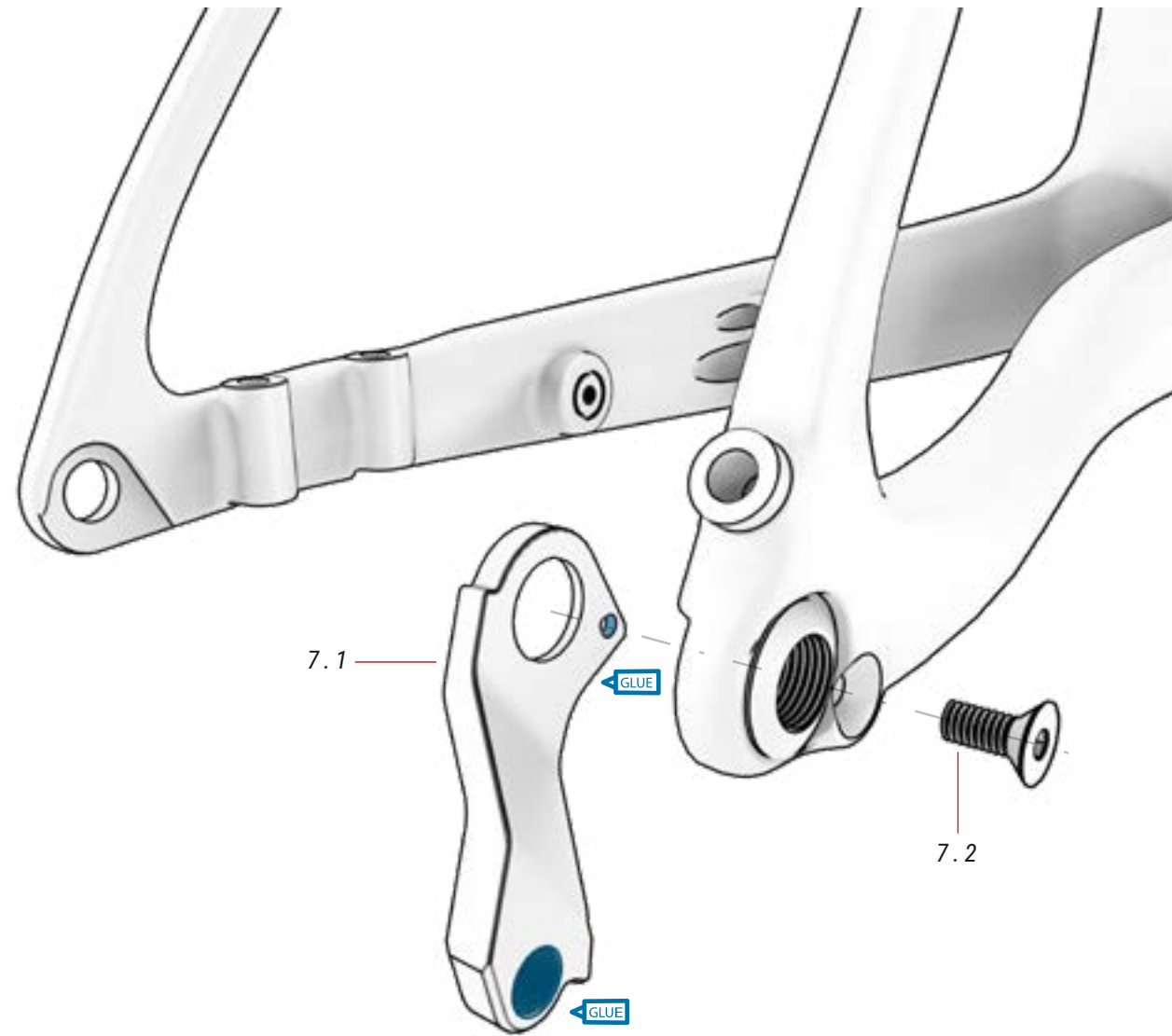

07 HANGER

ref.: 391732200

No.	Item	Quantity
7.1	Hanger	1
7.2	Bolt	1

FRONT DERAILLEUR BRACKET

EC282 / EC262 / EC182 / EC162

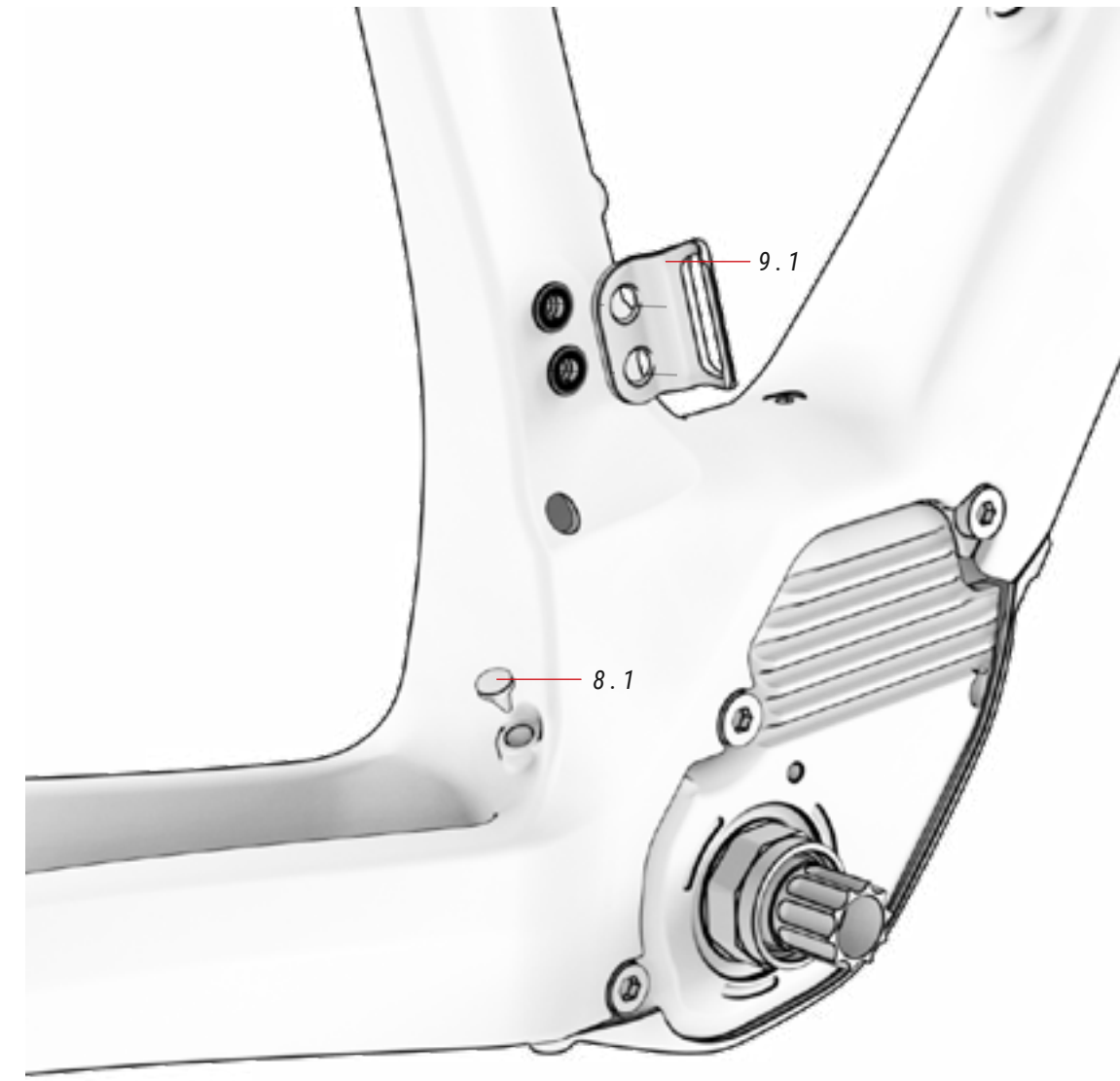

09 FRONT DERAILLEUR BRACKET

ref.: 387449500

No.	Item	Quantity
9.1	Front derailleur bracket	1

08 CABLE GLAND GROMMET

ref.: 391841600

No.	Item	Quantity
8.1	Cover	1

MOTOR

EC162 / EC182 / EC262 / EC122 / EC142 / EC222 / EC242

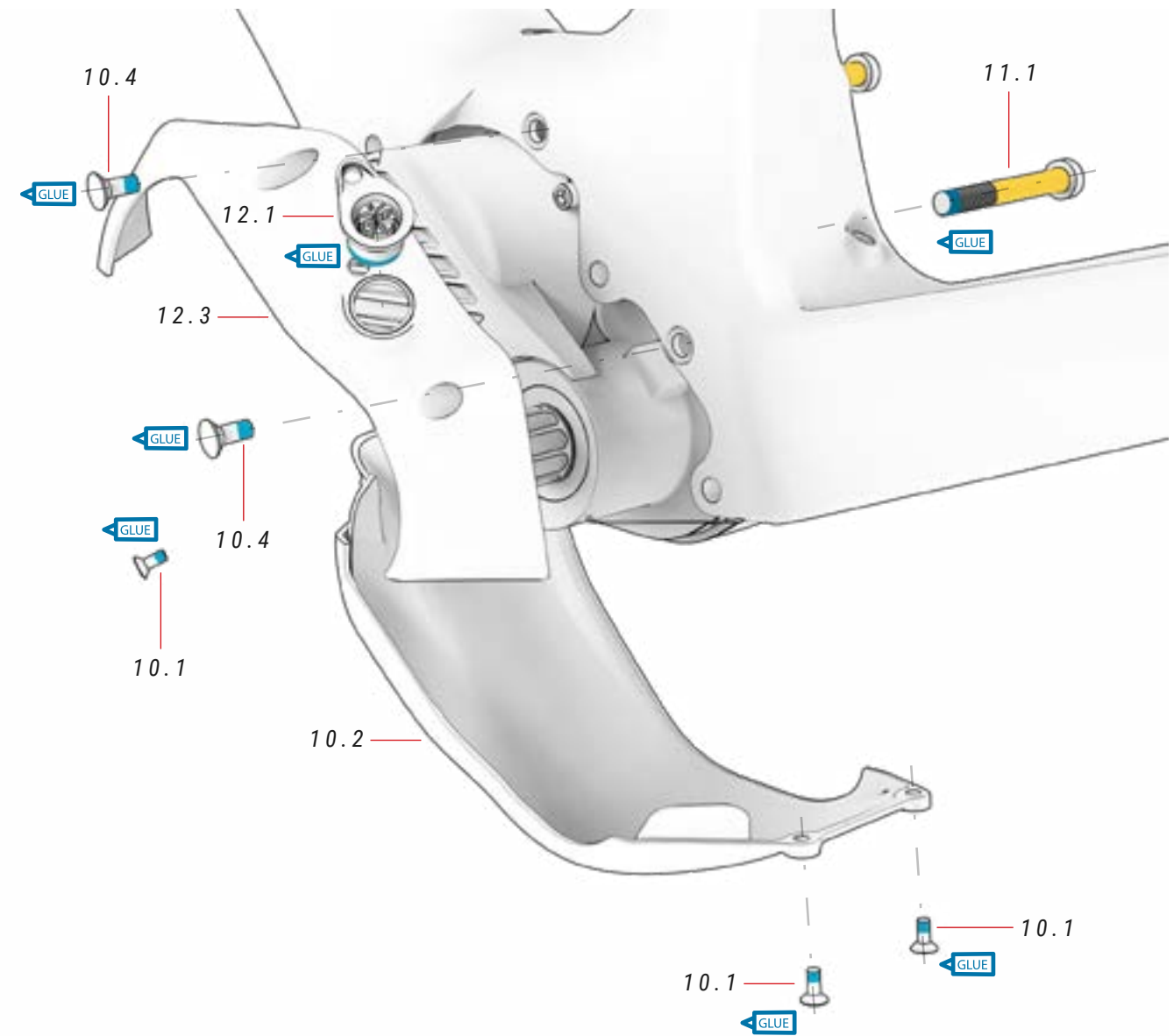
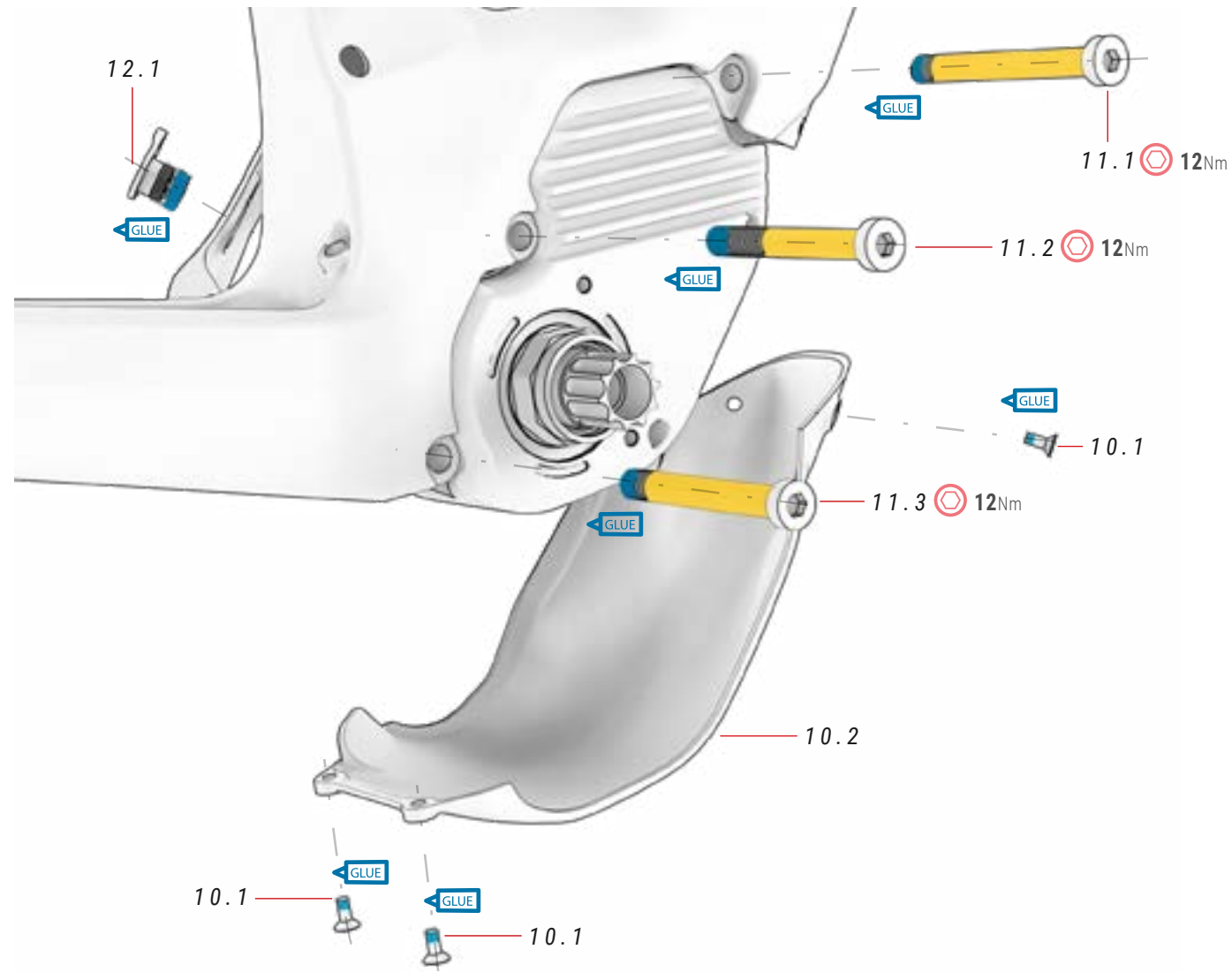

10 MOTOR COVER

ref.: 386222700

No.	Item	Quantity
10.1	Lower motor cover bolts	4
10.2	Lower motor cover	1
10.3	Side motor cover	1
10.4	Side motor cover bolts	2

11 MOTOR BOLTS

ref.: 381549600

No.	Item	Quantity
11.1	ø13*4.4/ø8/M8*P1.25*20/87	1
11.2	ø13*4.4/ø8/M8*P1.25*20/82	1
11.3	ø12*4.5/ø8/M8*P1.25*15/70	1

12 CHARGING PORT

ref.: 386129800

No.	Item	Quantity
12.1	Charging port	1

BATTERY HOLDER

EC122 / EC142 / EC222 / EC242 / EC312 / EC642 / EC502 / EC512 / EC622

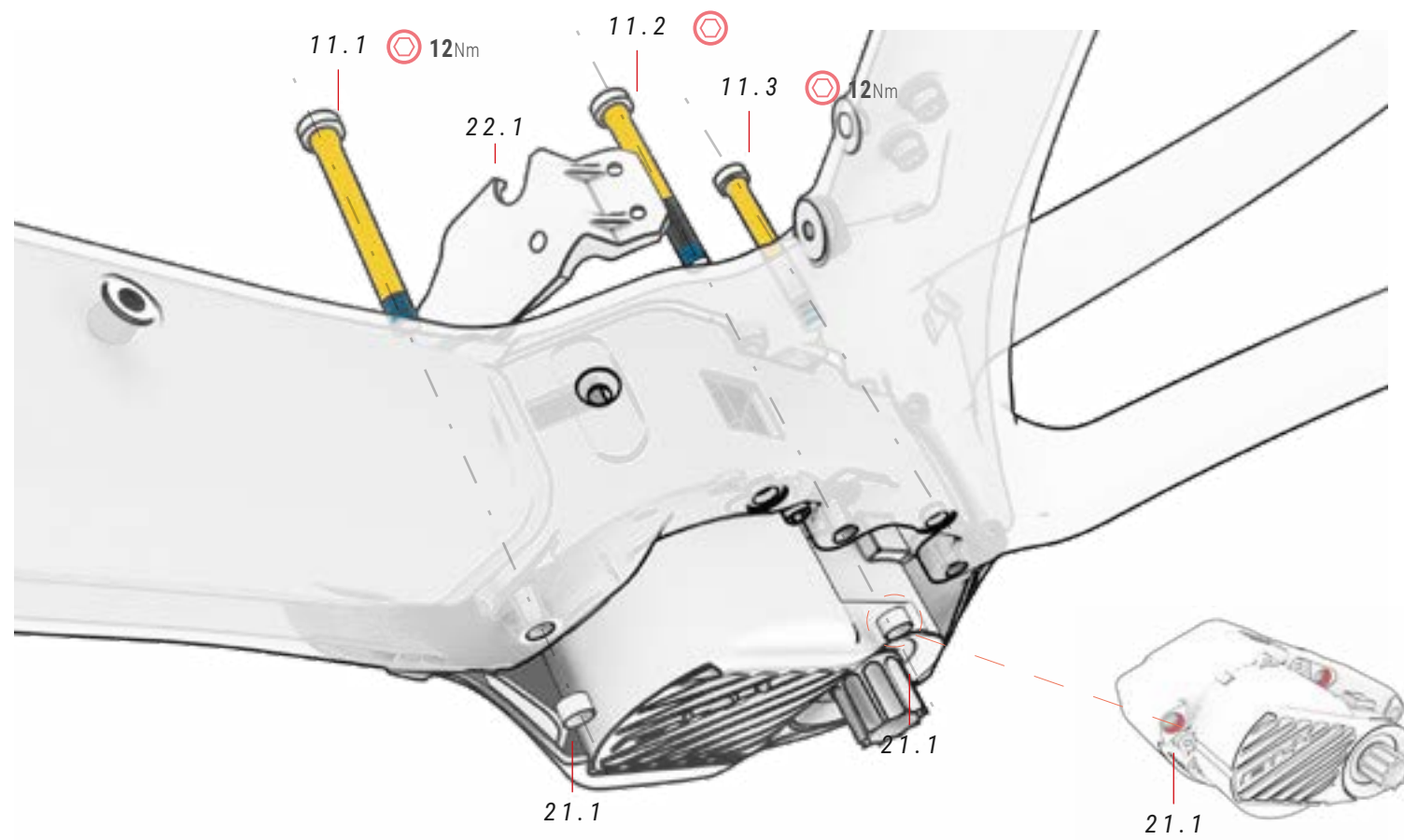

⚠ Insert the bushing in the motor holes.

21 MOTOR BUSHING

ref.: 387462300

Nº	Item	Quantity
21.1	8.5x5 Guide	2

22 SOPORTE BATERÍA

ref.: 387328900

Nº	Item	Quantity
22.1	Soporte batería	1

MOTOR COVER

EC312 / EC412 / EC502 / EC512 / EC622 / EC642

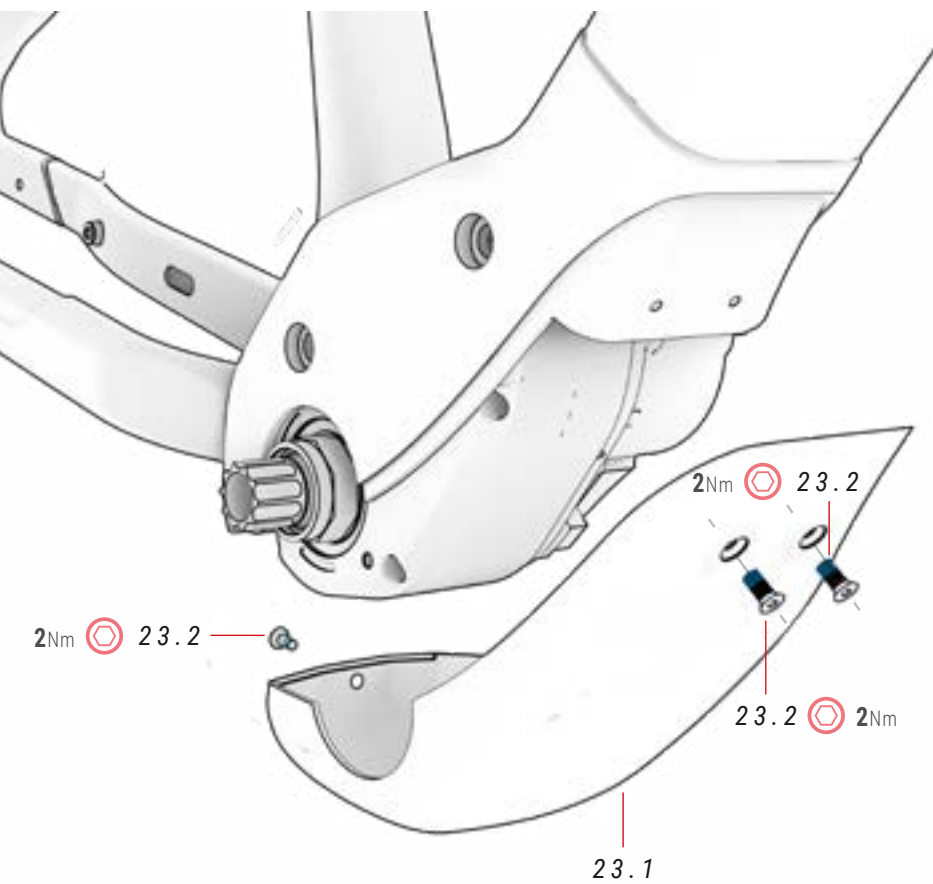

23 MOTOR COVER

ref.: 386222600

No.	Item	Quantity
23.1	Motorcover	1
23.2	Motor cover bolt M4xP0.7x10mm	3

XPRO BOTTLE HOLDER

EC282 / EC262 / EC182 / EC162 / EC242 / EC222 / EC142 / EC122 / EC642 / EC622

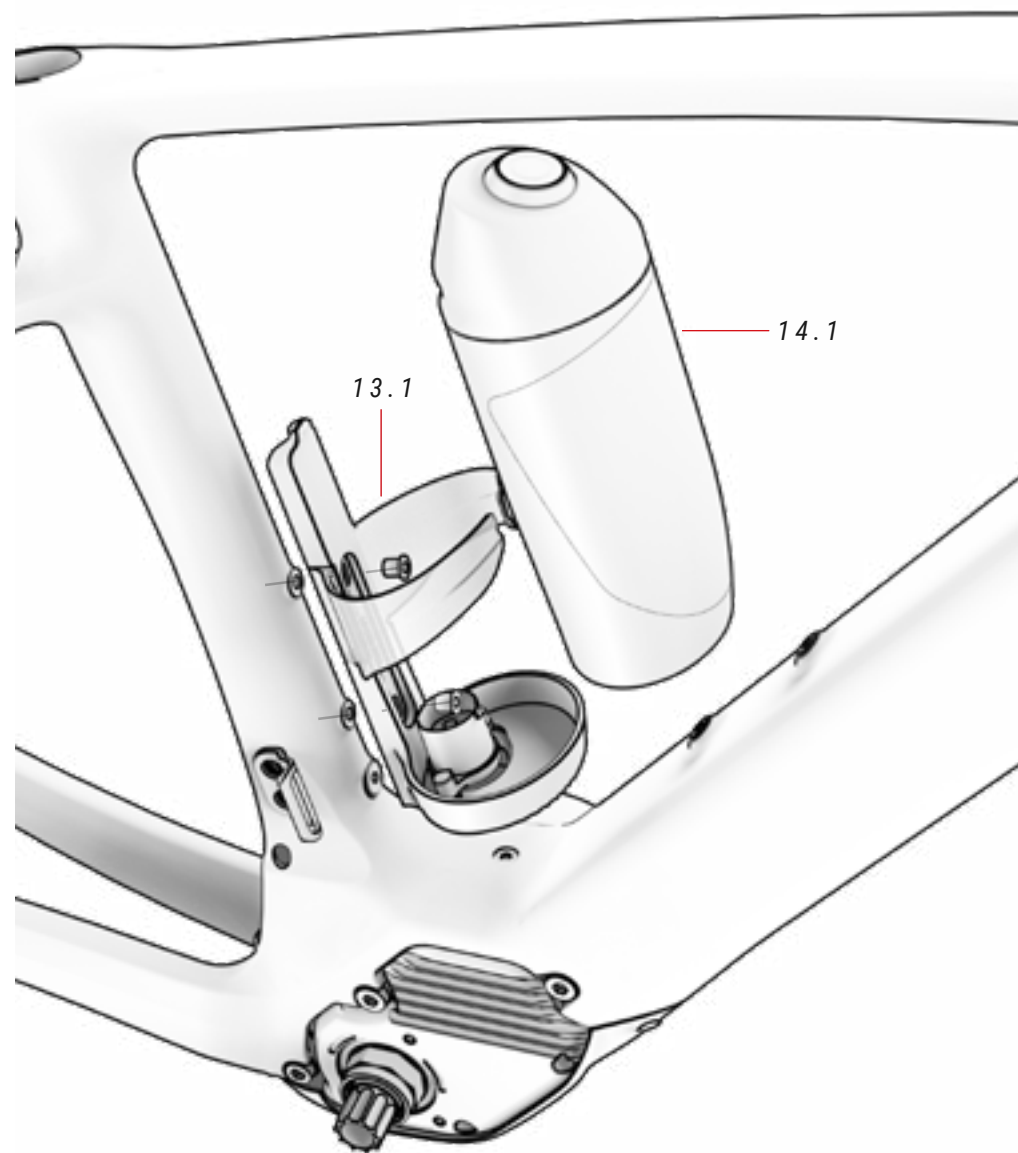

XPRO BOTTLE HOLDER
ASSEMBLY VIDEO

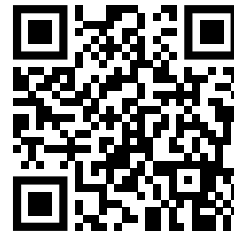

0

<https://youtu.be/UrMfZvXCPnA>

⚡ Refer to the section "Wiring diagrams of the electrical system" in this manual for information about the proper fitting and installation of all electrical components.

⚠ Excessively long bolts on the down tube may cause damage to the battery that is not covered by the warranty. Never force the bolts.

13 XPRO BOTTLE HOLDER KIT ref.: 387331100

No.	Item	Quantity
13.1	XPRO bottle holder	1

14 XPRO BOTTLE ref.: 387331000

No.	Item	Quantity
14.1	XPRO bottle	1

SPEED SENSOR MAGNET

ALL MODELS

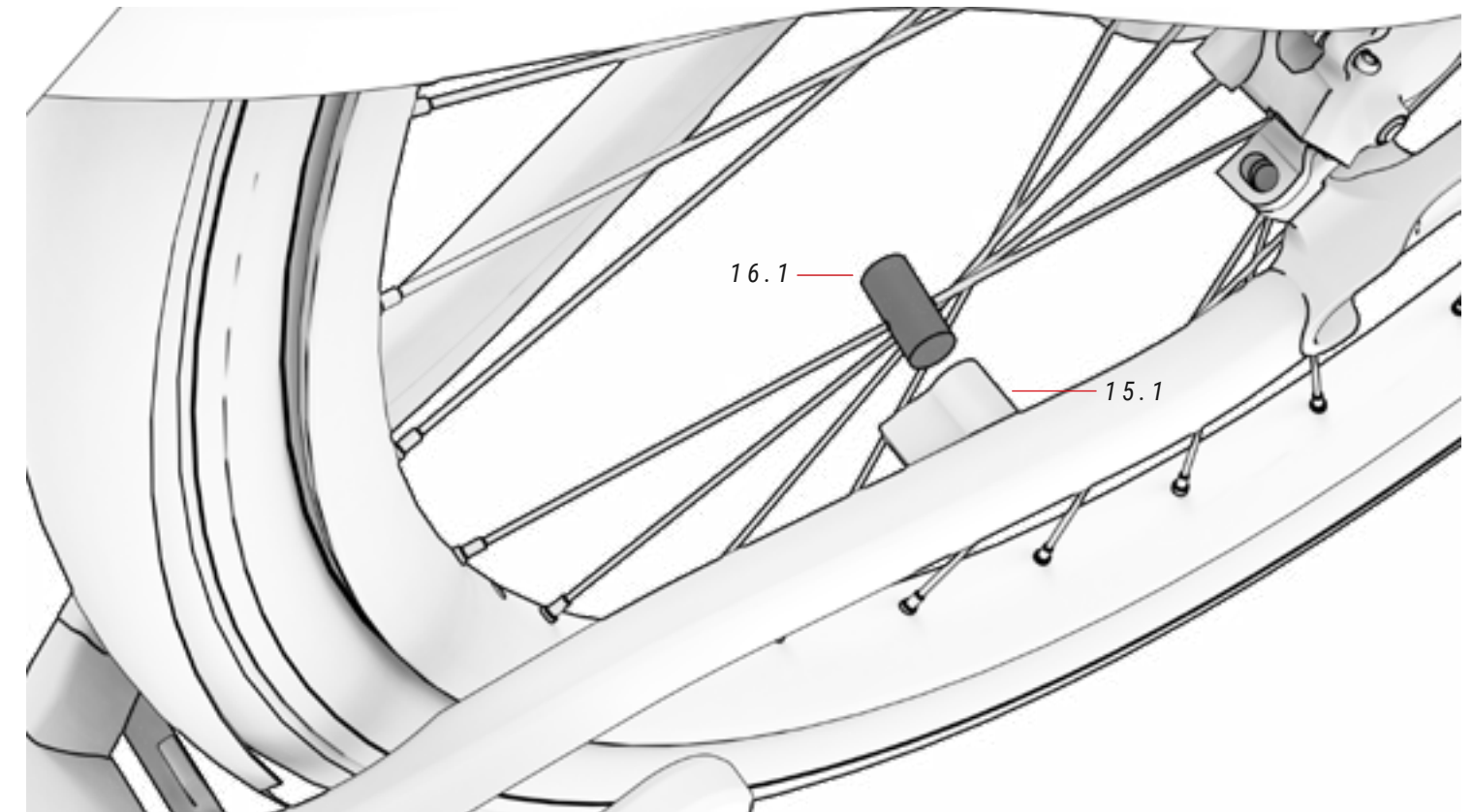

15 SPEED SENSOR ref.: 387332400

No.	Item	Quantity
15.1	Speed sensor	1

16 SPEED SENSOR MAGNET ref.: 387325300

No.	Item	Quantity
16.1	Speed sensor magnet	1

CHAIN GUARD

EC512 / EC502 / EC412 / EC312

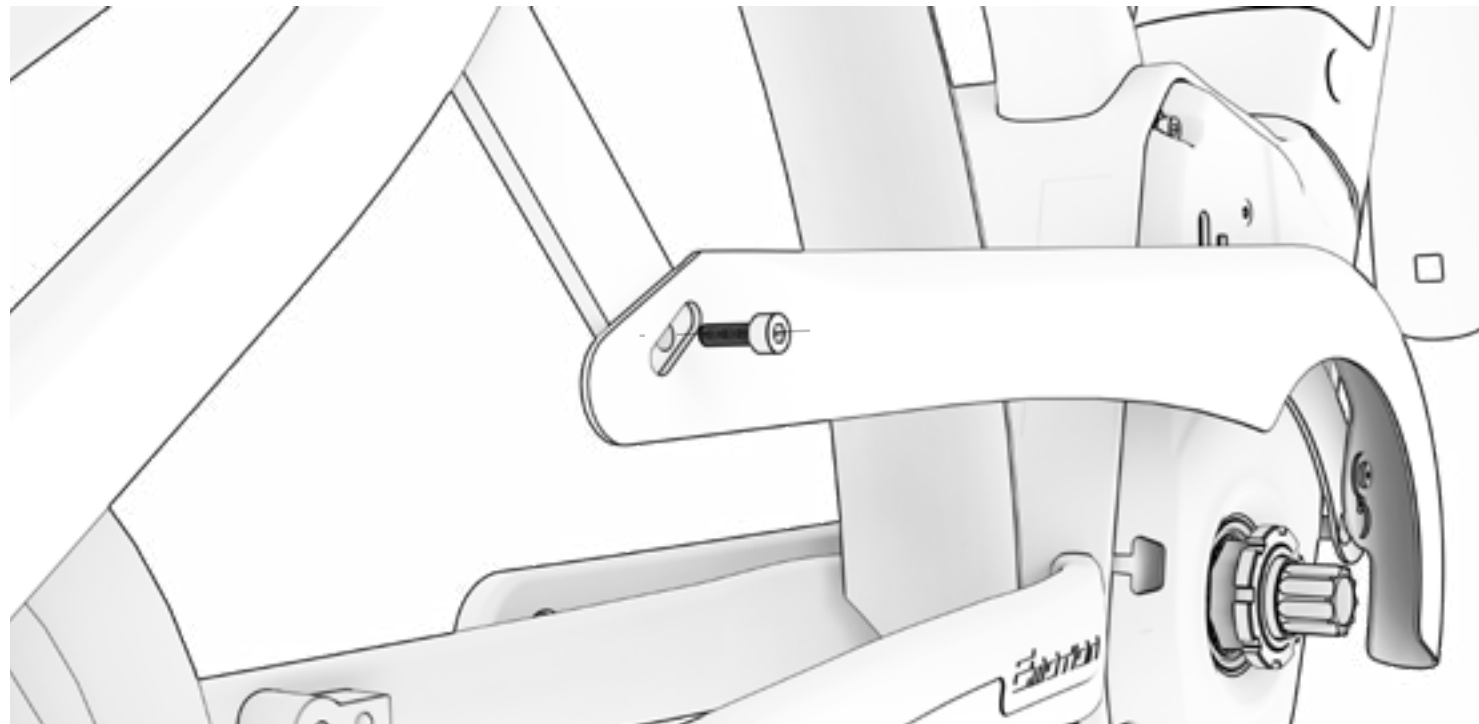
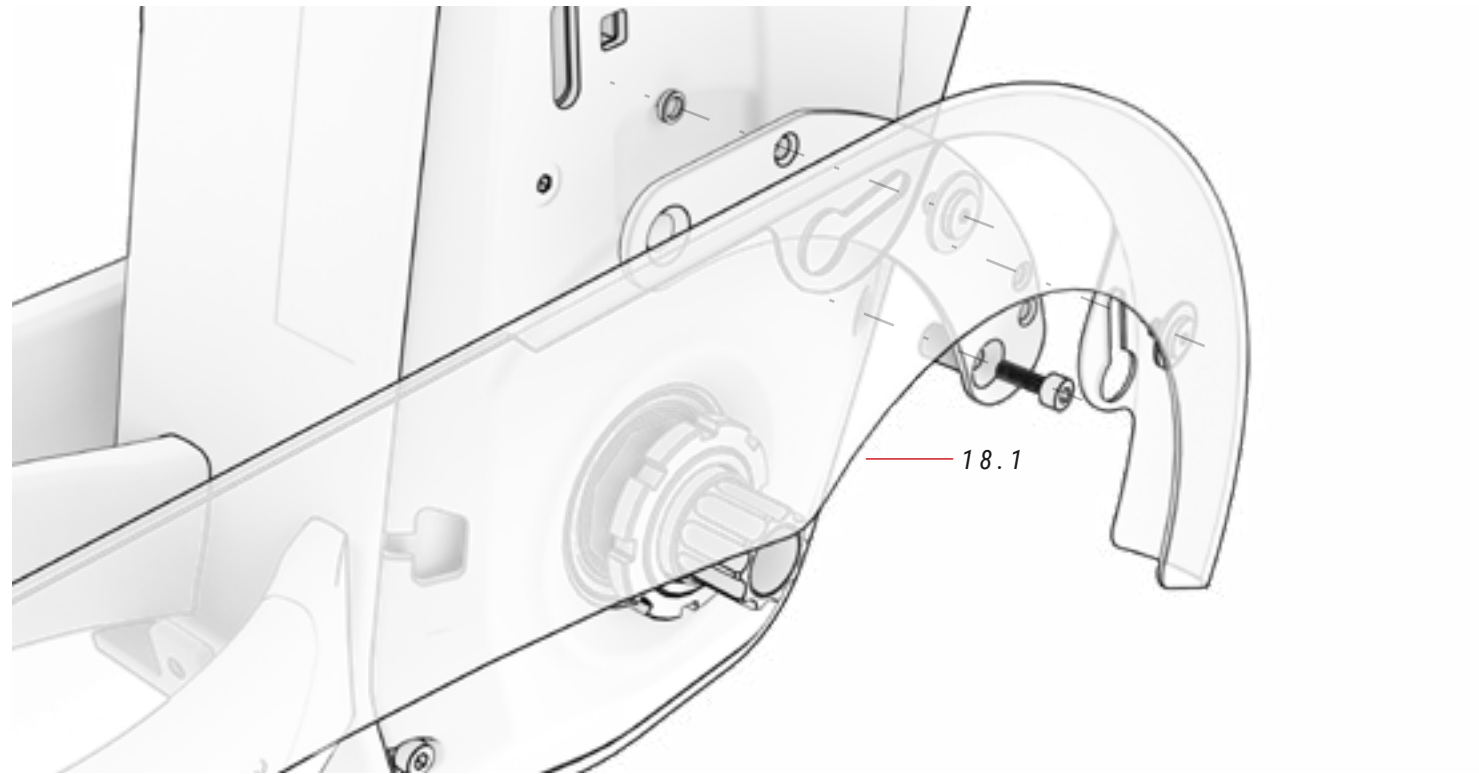

REAR PADLOCK

EC512 / EC502 / EC412 / EC312

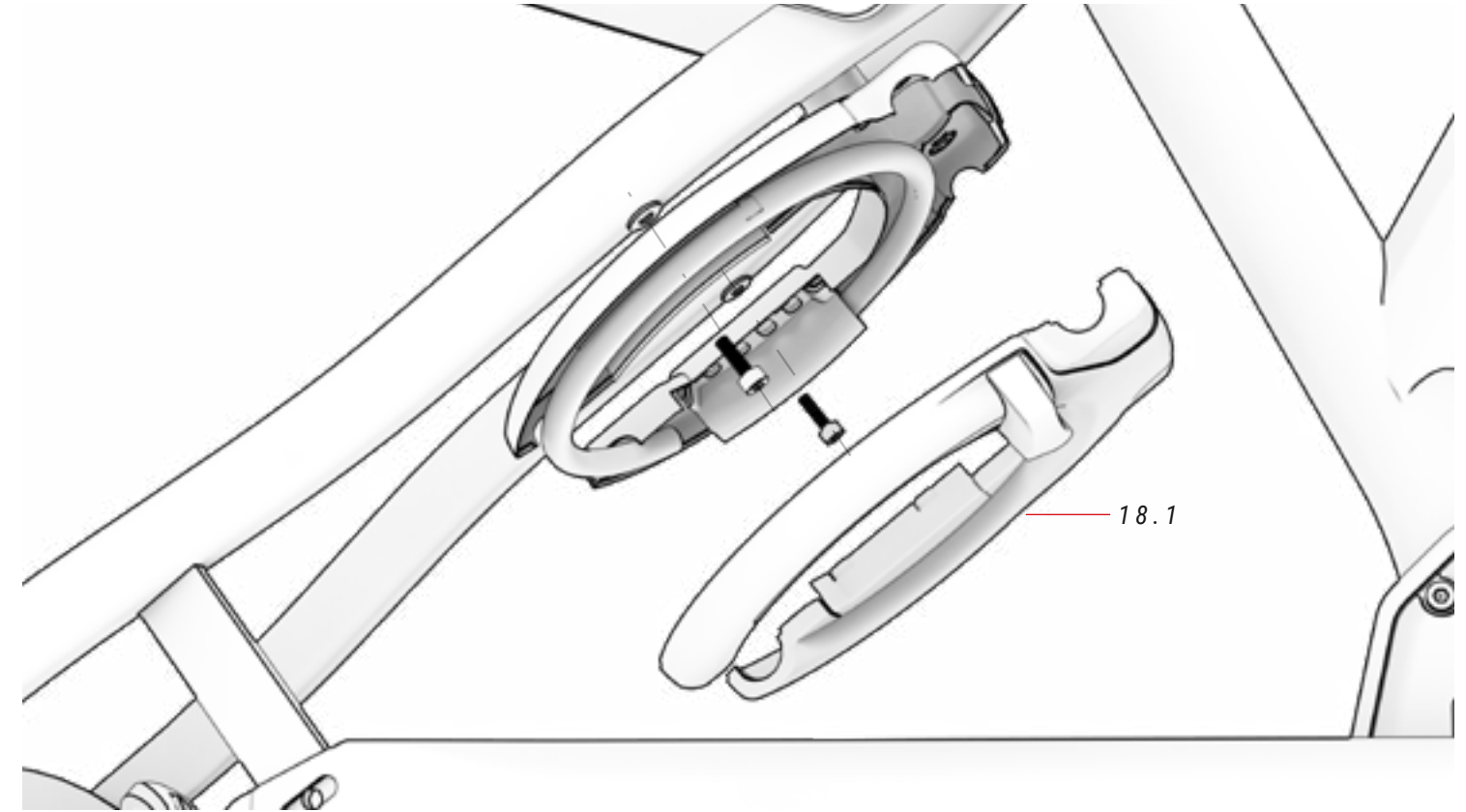

17 CHAIN GUARD

ref.: 364273200

No.	Item	Quantity
17.1	Chain guard	1

18 REAR PADLOCK

No.	Item	Quantity
18.1	Rear padlock	1

PANNIER RACK

EC512 / EC502 / EC412 / EC312

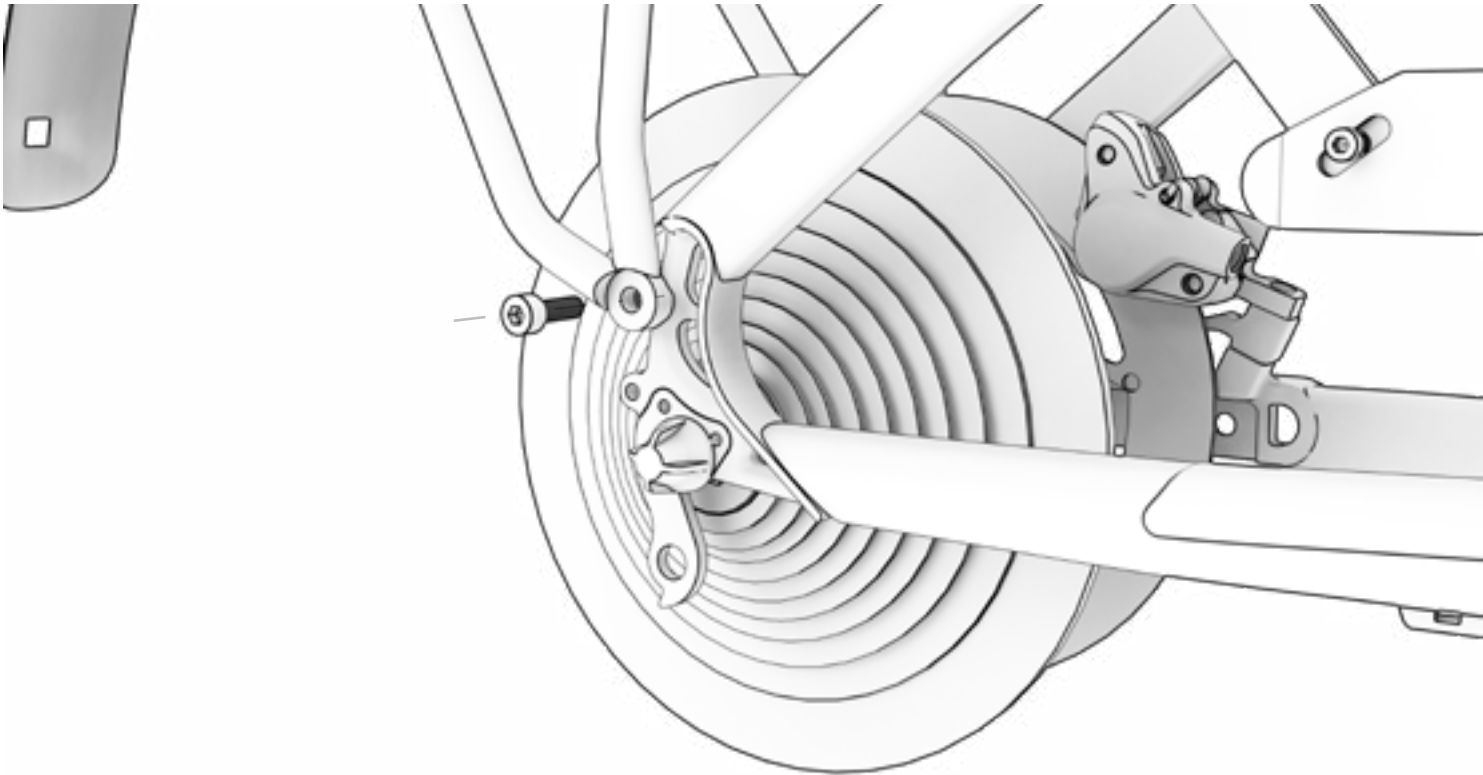
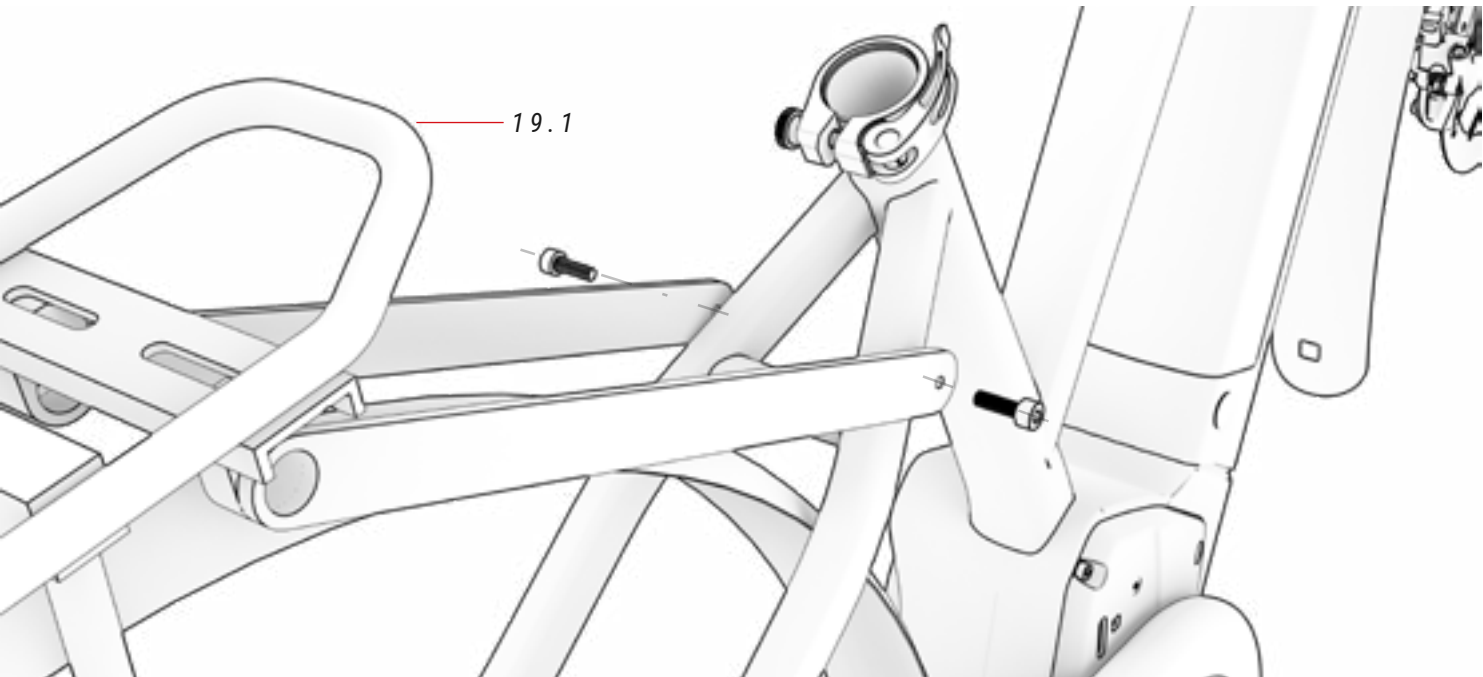

CHAIN GUARD FOR CHAINSTAY

EC312 / EC412 / EC502 / EC512 / EC622

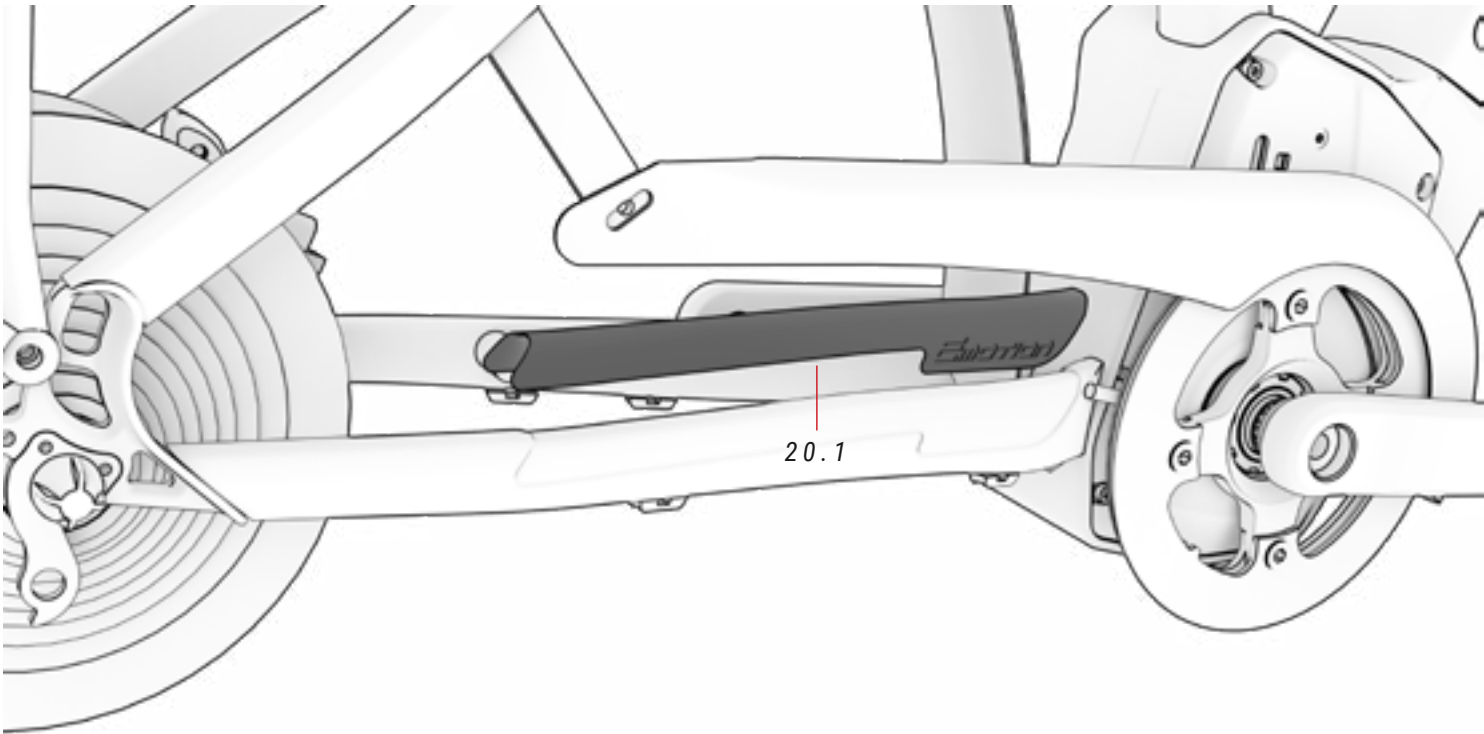

19 PANNIER RACK

No.	Item	Quantity
19.1	Pannier rack	1

20 CHAINSTAY GUARD

ref.: 393233000

No.	Item	Quantity
20.1	Chainstay guard	1

REAR LIGHT

EC512 / EC502 / EC412 / EC312

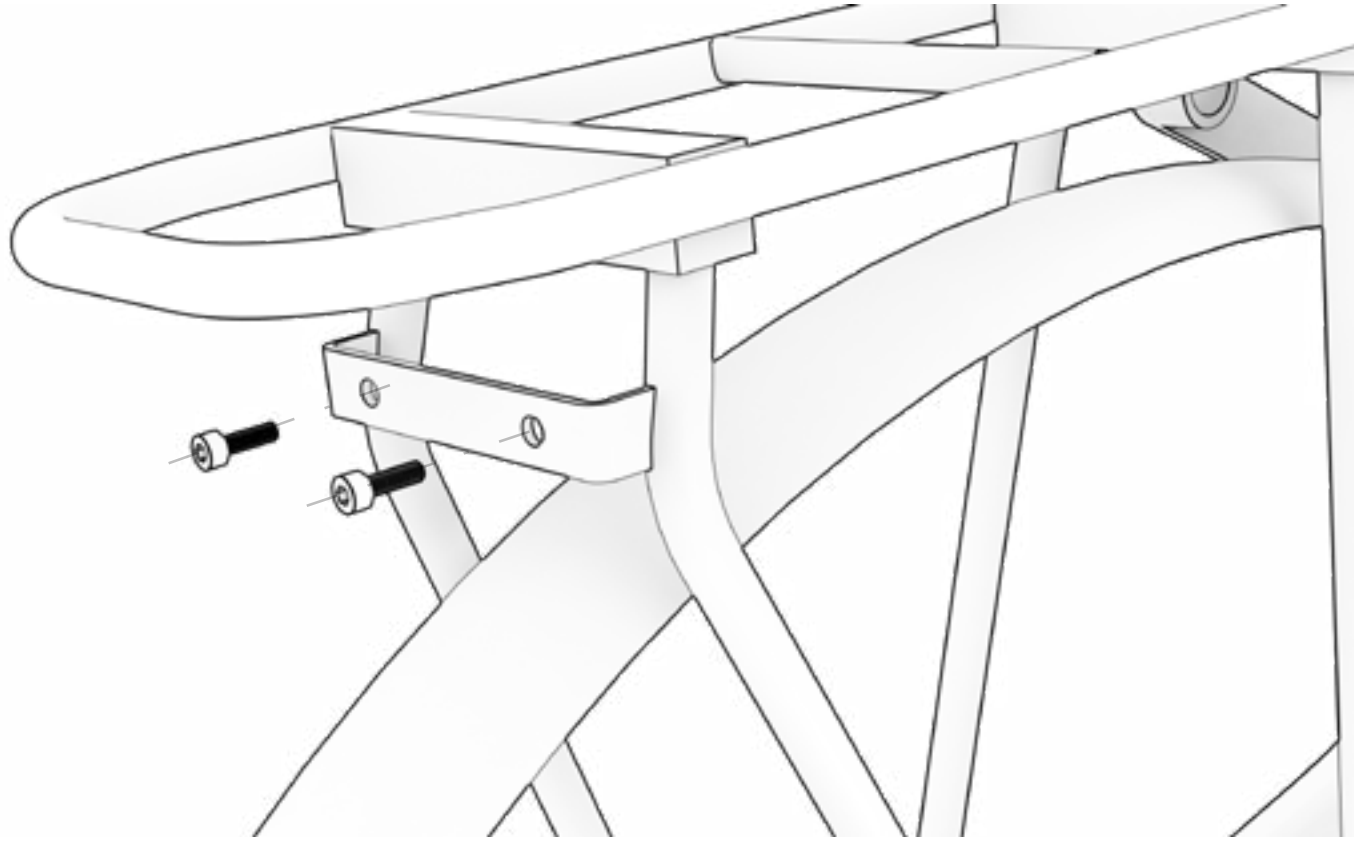

HEADLIGHT

EC512 / EC502 / EC412 / EC312

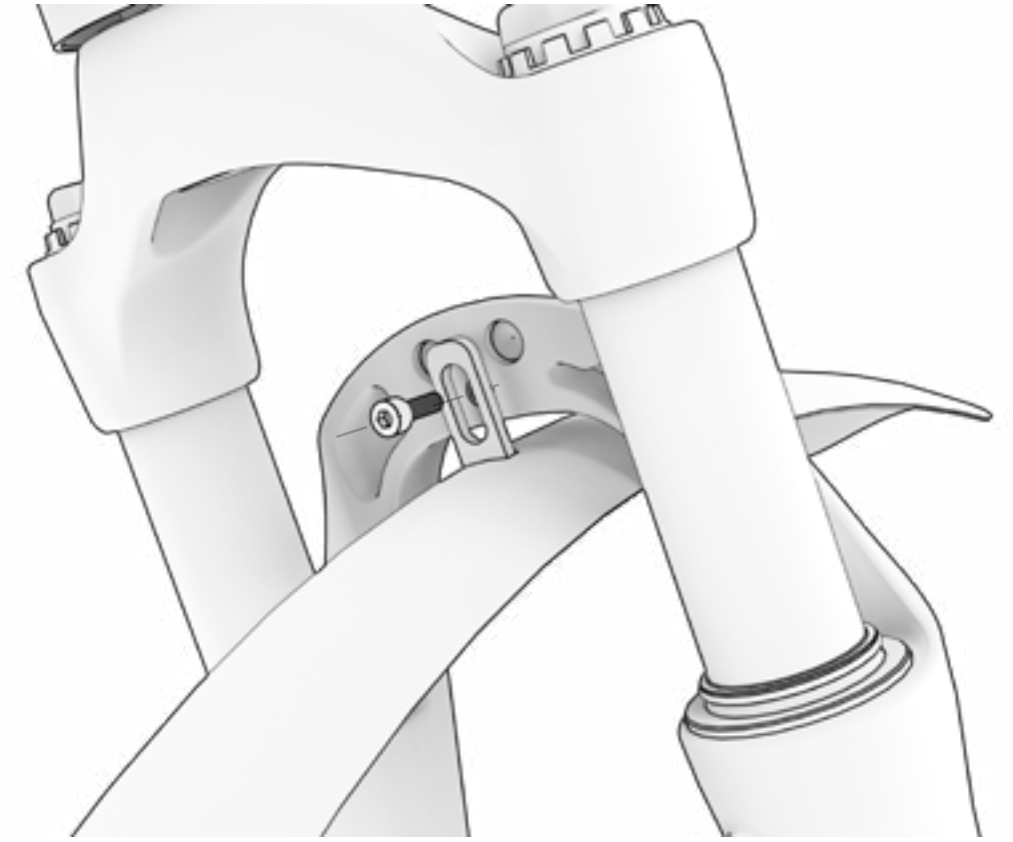

CABLING OF THE MECHANICAL PARTS

The images below show the routing configuration for the mechanical component cables. The cables will remain protected inside the frame triangle until they come out through the motor cover for ease of maintenance.

EC282 / EC262 / EC182 / EC162 / EC242 / EC222 / EC142 / EC122

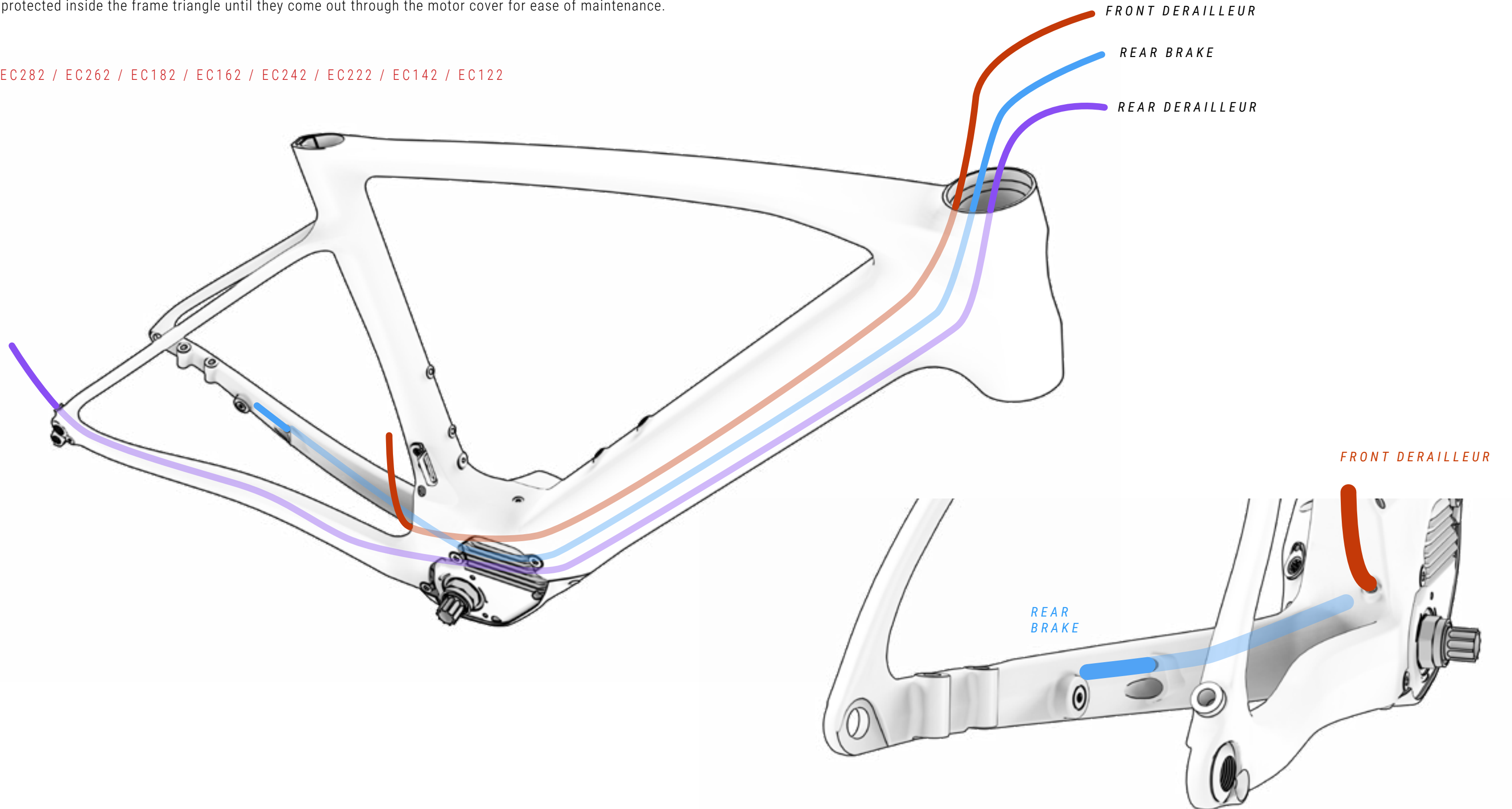

CABLING OF THE ELECTRICAL SYSTEM'S PARTS

EC282 / EC262 / EC182 / EC162 / EC242 / EC222 / EC142 / EC122

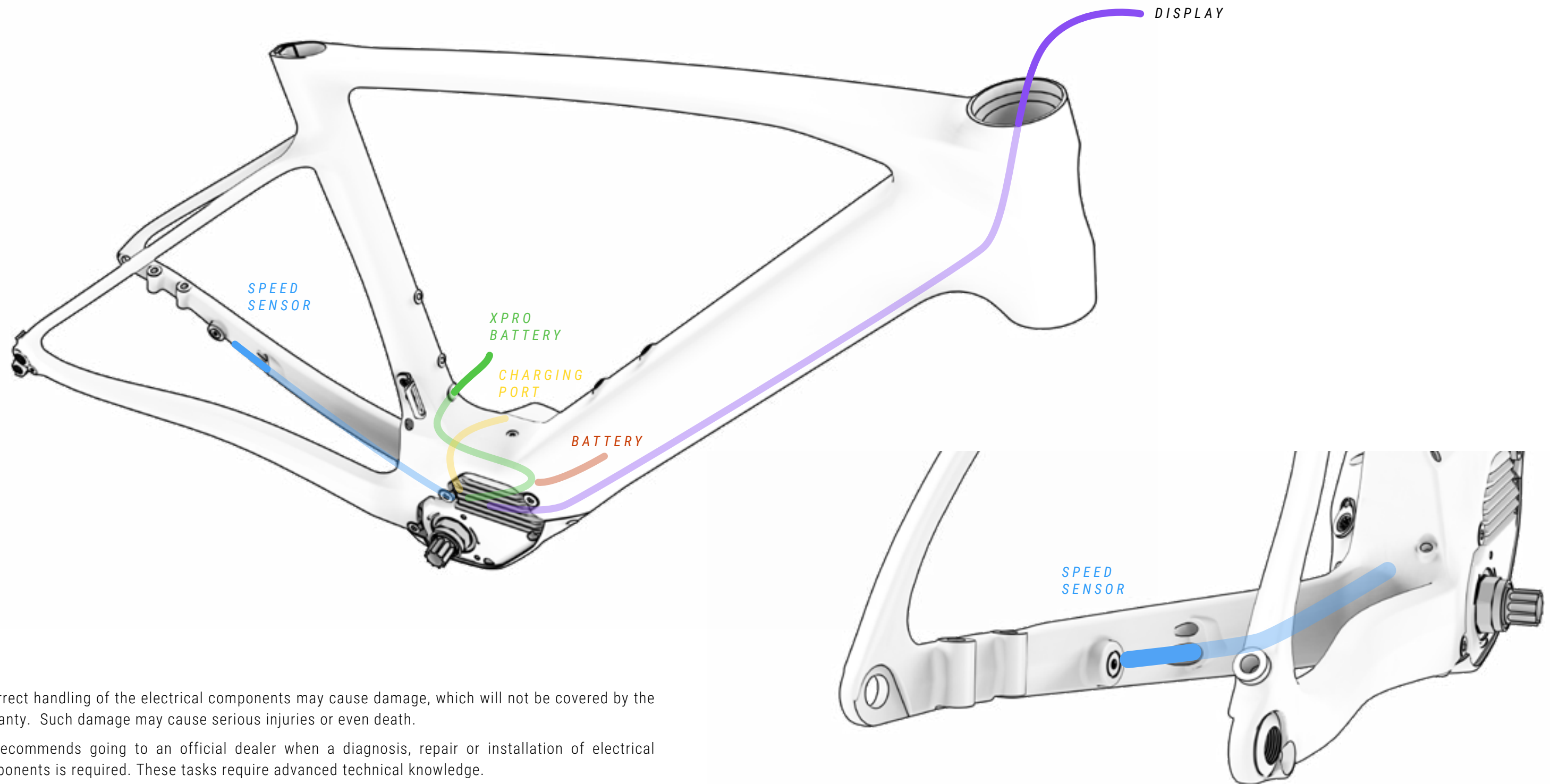

⚠ Incorrect handling of the electrical components may cause damage, which will not be covered by the warranty. Such damage may cause serious injuries or even death.

BH recommends going to an official dealer when a diagnosis, repair or installation of electrical components is required. These tasks require advanced technical knowledge.

WIRING DIAGRAM OF THE ELECTRICAL SYSTEM'S PARTS

EC282 / EC262 / EC182 / EC162 / EC242 / EC222 / EC142 / EC122

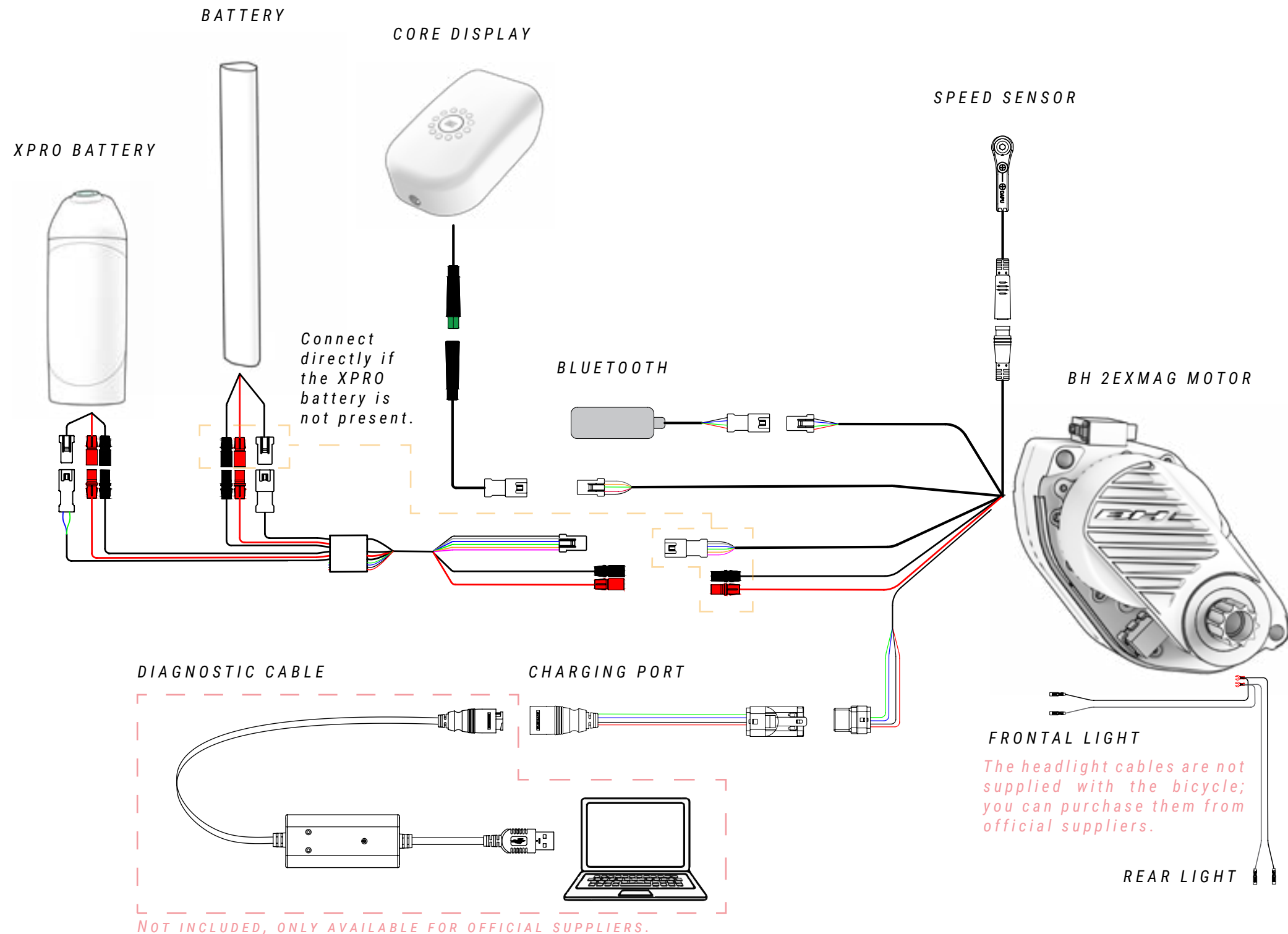

⚠ Incorrect handling of the electrical components may cause damage, which will not be covered by the warranty. Such damage may cause serious injuries or even death.

BH recommends going to an official dealer when a diagnosis, repair or installation of electrical components is required. These tasks require advanced technical knowledge.



⚠ When electrical connections come into contact with damp spots or are clogged due to external contamination, a chemical reaction occurs, causing a build-up of lead sulphate crystals in the connections. In other words, the copper on the contacts will rust, resulting in conductivity problems.

The warranty does not cover damage caused by incorrect maintenance of the bicycle's connections. To prevent rust, simply clean the connections (male and female) at regular intervals, using dielectric deoxidisers like the one shown in the image above.

WIRING DIAGRAM OF THE ELECTRICAL SYSTEM'S PARTS

EC642 / EC622 / EC512 / EC502 / EC412 / EC312

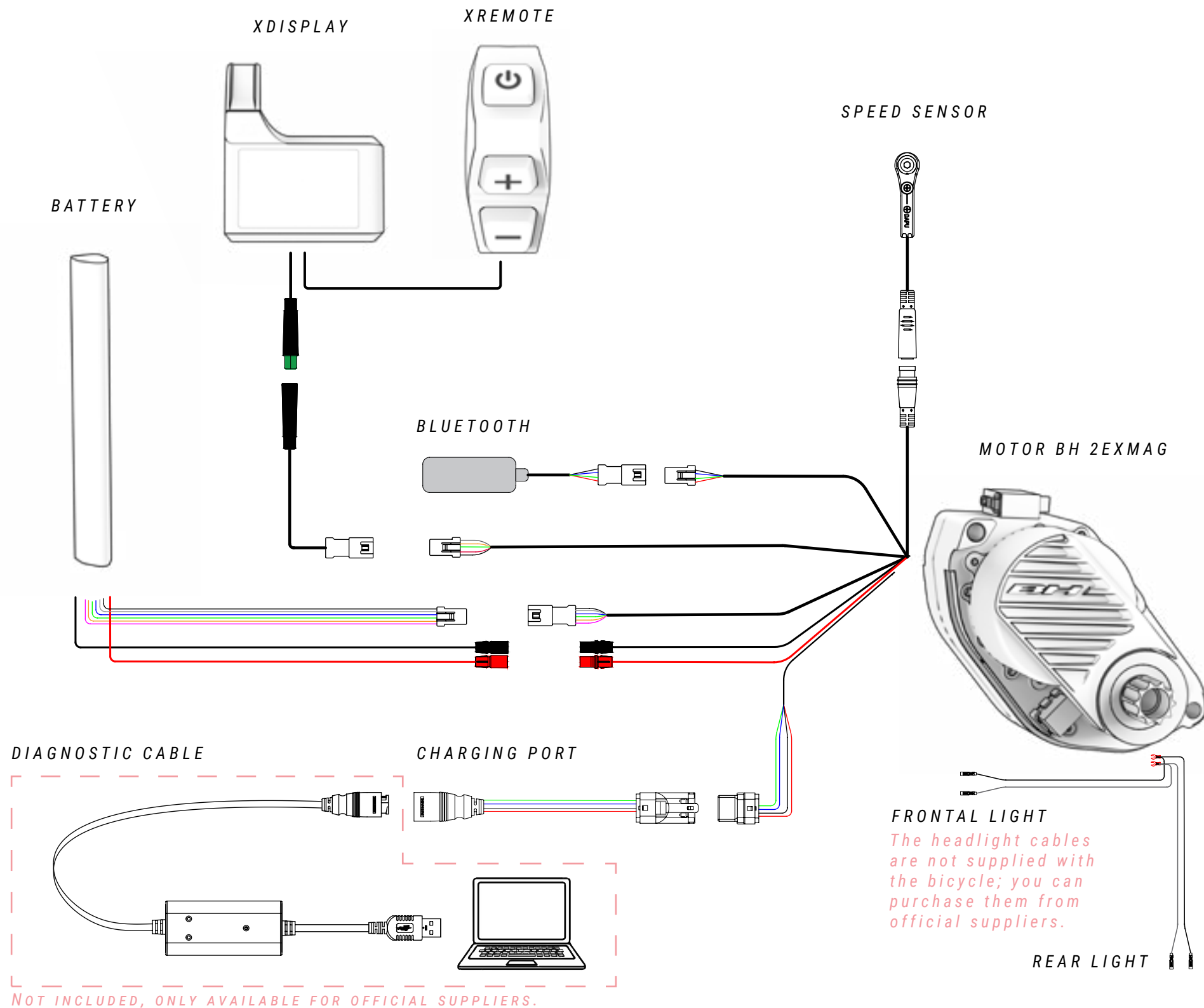

⚠ Incorrect handling of the electrical components may cause damage, which will not be covered by the warranty. Such damage may cause serious injuries or even death.

BH recommends going to an official dealer when a diagnosis, repair or installation of electrical components is required. These tasks require advanced technical knowledge.

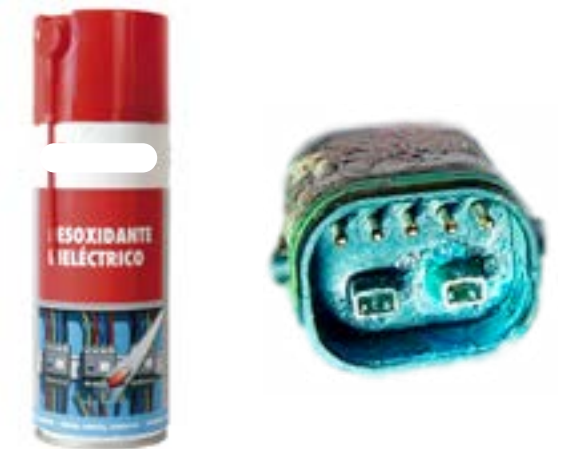

⚠ When electrical connections come into contact with damp spots or are clogged due to external contamination, a chemical reaction occurs, causing a build-up of lead sulphate crystals in the connections. In other words, the copper on the contacts will rust, resulting in conductivity problems.

The warranty does not cover damage caused by incorrect maintenance of the bicycle's connections. To prevent rust, simply clean the connections (male and female) at regular intervals, using dielectric deoxidisers like the one shown in the image above.

10 DECLARATION OF CONFORMITY

EU Declaration of Conformity

The manufacturer: BH BIKES EUROPE, SL
c/ Perretagana 10,
01015 Vitoria, Spain

Hereby declares that the following products:

Product description:  Cycles –Electrically power assisted cycles –EPAC Bicycles

Models designation:

Atom 27,5, Atom 29, Atom City, Atom City Pro, Atom City Wave, Atom City Wave Pro, Atom Cross, Atom Cross Pro, Atom Diamond Wave Pro, Atom Jet, Atom Jet Pro, Atom Lynx 5.5, Atom Lynx 5.5 Pro, Atom Lynx 8.0, Atom Lynx 8.1, Atom Lynx 8.2 Pro, Atom Pro, Atom Street, Atom Street Pro, Atom Suv Pro.

AtomE City Wave Pro, AtomE Diamond Wave Pro, AtomE Cross Pro, AtomE Jet Pro, AtomE Lynx 8.0, AtomE Lynx 8.2, AtomE Pro, AtomE Suv Pro, AtomE Suv Pro-S, AtomE Suv Pro-SE.

AtomS 27,5 Pro, AtomS 29 Pro, AtomS City Wave Pro, AtomS City Wave Pro-S, AtomS Cross Pro, AtomS Cross Pro-S, AtomS Diamond Pro, AtomS Diamond Wave Pro, AtomS Diamond Wave Pro-S, AtomS Jet Pro, AtomS Jet Pro-S, AtomS Pro, AtomS Pro-S, AtomS Street Pro, AtomS Suv Pro, AtomS Suv Pro-S.

AtomX Carbon Lynx 5.5 Pro, AtomX Carbon Lynx 5.5 Pro-S, AtomX Carbon Lynx 6 Pro, AtomX Carbon Lynx 6 Pro-S, AtomX Carbon Lynx 6 Pro-SE, AtomX Cross Nitro, AtomX Cross Pro, AtomX Cross Pro-S, AtomX Lynx 5.5 Pro, AtomX Lynx 5.5 Pro-L, AtomX Lynx 5.5 Pro-S, AtomX Lynx 6 Pro, AtomX Lynx 6 Pro-S, AtomX Lynx 6 Pro-SE, AtomX Lynx Pro 8.2, AtomX Lynx Pro 8.4, AtomX Lynx Pro 9.0, AtomX Lynx Pro 9.2, AtomX Lynx Pro 9.4, AtomX Lynx Carbon Pro 8.7, AtomX Lynx Carbon Pro 8.8, AtomX Lynx Carbon Pro 9.7, AtomX Lynx Carbon Pro 9.8, AtomX Lynx Carbon Pro 9.9, AtomX Pro, AtomX Pro-S.

Core 29, Core Pro, Core City Wave, Core Cross, Core Gravel X 2.2, Core Gravel X 2.4, Core Gravel X Carbon 2.6, Core Gravel X Carbon 2.7 Pro, Core Jet, Core Pro, Core Race 1.2, Core Race 1.4, Core Race Carbon 1.5, Core Race Carbon 1.6, Core Race Carbon 1.8, Core Race Carbon 1.8 Pro, Core Race Carbon 1.9 Pro, Core Street.

iLynx Race Carbon 7.6 LT, iLynx Race Carbon 7.7 LT, iLynx Race Carbon 7.8 LT Pro, iLynx Race Carbon 7.9 Pro, iLynx Race Carbon 8.0 LT, iLynx Race Carbon 8.2 LT, iLynx Race Carbon 8.4 LT Pro, iLynx Race Carbon 8.6 Pro, iLynx Trail 8.0, iLynx Trail 8.1, iLynx Trail 8.2, iLynx Trail Carbon 8.6, iLynx Trail Carbon 8.7, iLynx Trail Carbon 8.8 Pro, iLynx Trail Carbon 8.9 Pro.

iLynx+ Trail Carbon 8.7, iLynx+ Trail Carbon 8.8, iLynx+ Trail Carbon Pro 8.9, iLynx+ Enduro Carbon 9.7, iLynx+ Enduro Carbon 9.8, iLynx+ Enduro Carbon Pro 9.9.

iAerolight 1.7, iAerolight 1.8, iAerolight Pro 1.9.

Xtep Carbon Lynx 5.5 Pro, Xtep Carbon Lynx 5.5 Pro-S, Xtep Carbon Lynx 6 Pro, Xtep Carbon Lynx 6 Pro-S, Xtep Carbon Lynx 6 Pro-SE, Xtep Cross Pro, Xtep Lynx 5.5 Pro, Xtep Lynx 5.5 Pro-L, Xtep Lynx 5.5 Pro-S, Xtep Lynx 5.5 Pro-SE, Xtep Lynx Carbon 8.7 Pro, Xtep Lynx Carbon 8.8 Pro, Xtep Lynx Carbon 9.7 Pro, Xtep Lynx Carbon 9.8 Pro, Xtep Lynx Carbon 9.9 Pro, Xtep Pro-S, Xtep Lynx Carbon Pro 0.7, Xtep Lynx Carbon Pro 0.8, Xtep Lynx Carbon Pro 0.9.

Year of manufacture: 2022 and 2023

Comply with all of the relevant requirements of the Machinery Directive (2006/42/EC).

Comply with Low Voltage Directive (LVD) 2014/35/EU

Comply with all of the relevant requirements of RD 339/2014, de 9 de Mayo.

Furthermore, the machine complies with all of the requirements of the Electromagnetic Compatibility Directive 2014/30/EU.

The production control is assured by our Quality Management System, which fulfills the requirements of the standard ISO 9001

The following harmonized standards have been applied:

DIN EN 15194 Cycles – Electrically power assisted cycles – EPAC bicycles;
DIN ISO 4210-1/2/3/4/5/6/7/8/9 Safety requirements for bicycles

Technical documentation filed at:

BH BIKES EUROPE, SL
c/ Perretagana 10,
01015 Vitoria, Spain

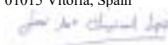

José Maria Chapinal
Quality Manager
BH BIKES EUROPE, SL

Rev.16

17/05/2022

Page 1 of 1

11 HELP AND ADDITIONAL RESOURCES

BH offers different channels to resolve your queries. In addition, you can join our global cyclist community on our social media.

TECHNICAL RESOURCES

You can find all of the resources you need to fine-tune your bicycle on the BH Bikes website. Click on the link below to access the user manuals, apps, warranties, display update files and videos that explain different operations:

<https://www.bhbikes.com/manuals>

You can also check out our step-by-step tutorials to learn how to maintain and fine-tune your bicycle on our specialised Youtube channel:

<https://www.youtube.com/user/ServicioTecnicoBH>

CONTACT US

Our authorised dealers have the necessary knowledge and resources to help you with anything you need in relation to your bicycle. Don't hesitate to contact your nearest store. You can find it by clicking on the link below:

https://www.bhbikes.com/es_INT/tiendas/buscador-de-tiendas

To contact us directly:

Tel.: + 34 945 13 52 02

info@bhbikes.com

P.I. Jundiz- Perretagana 10, 01015 Vitoria, Alava (Spain)

SOCIAL MEDIA

Join our global cyclist community. Discover the BH experiences of other cyclists and share yours.



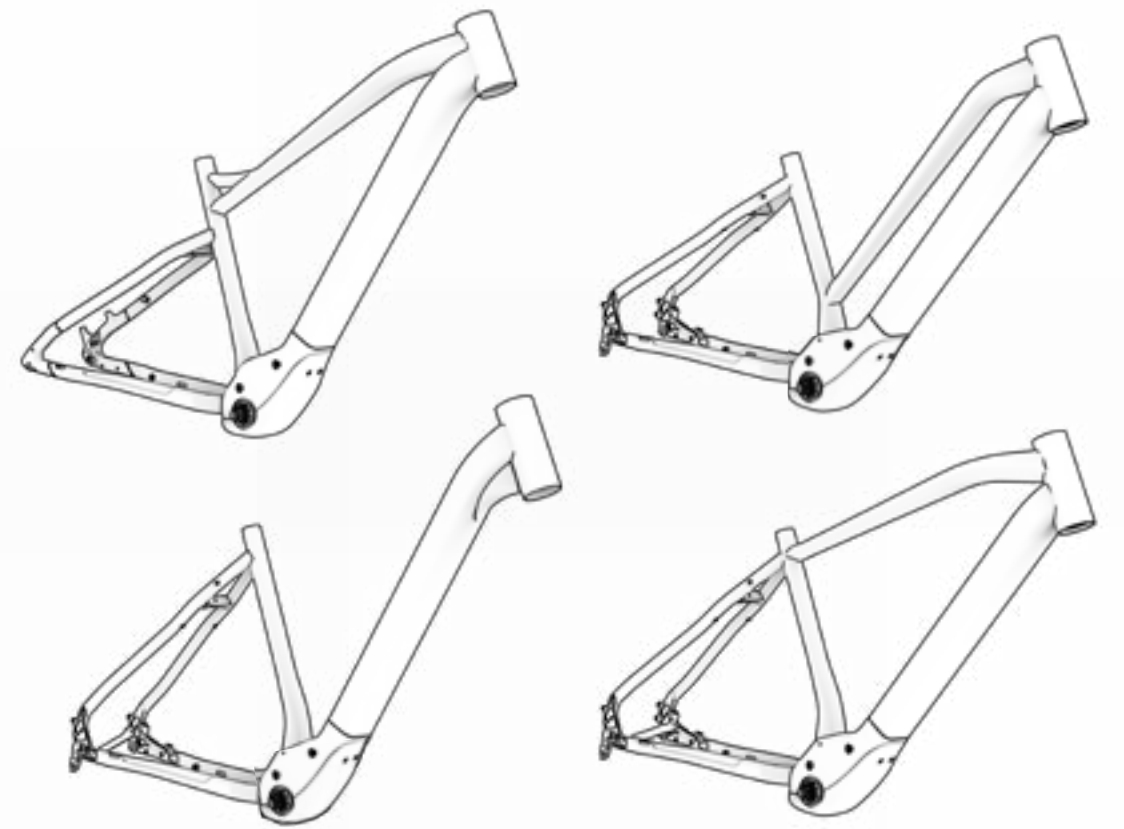
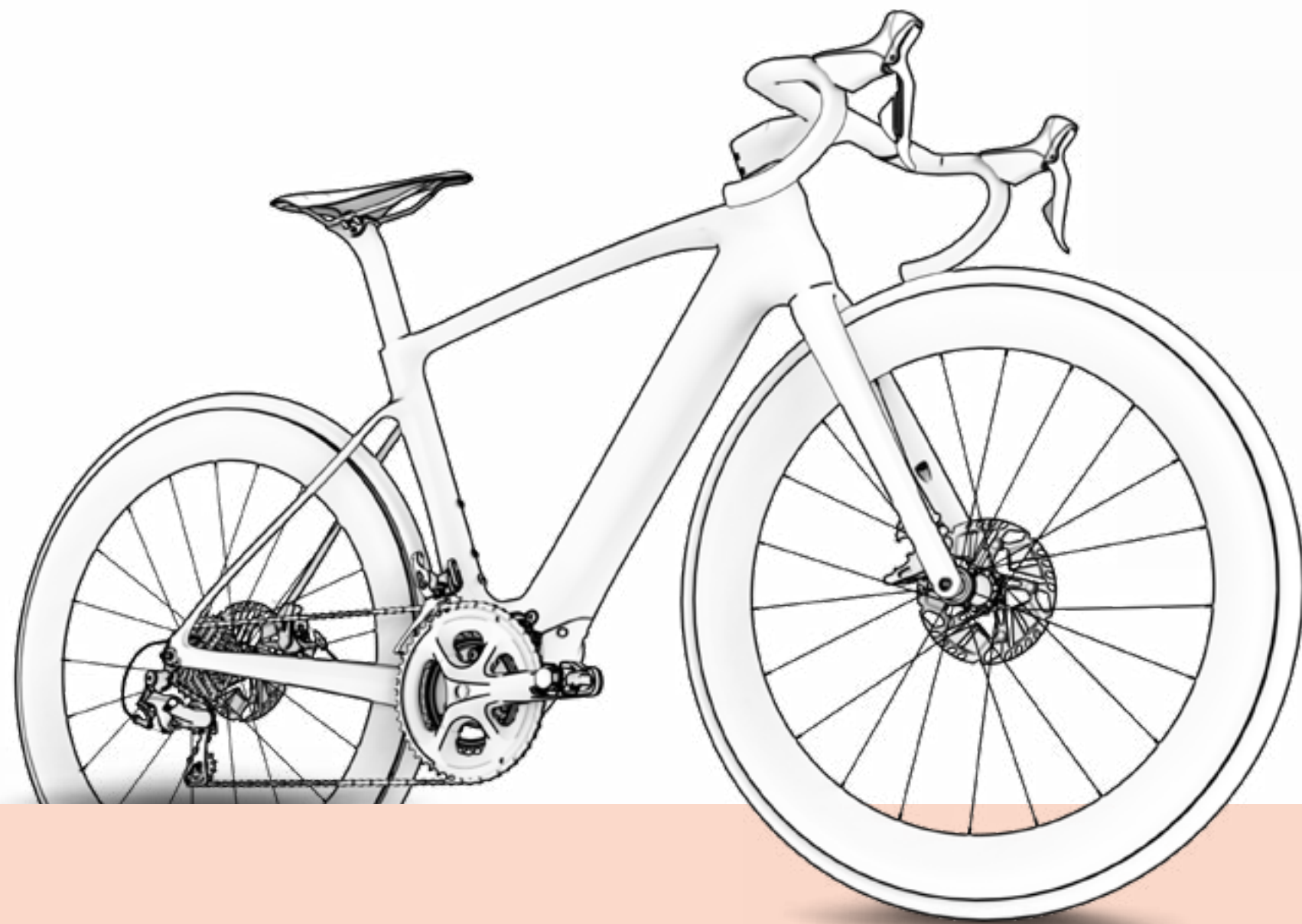

www.bhbikes.com



V0.0

