



# CONTENTS

<b>01 INTRODUCTION</b> .....	<b>3</b>
SYMBOLS .....	3
<b>02 BH WARRANTY</b> .....	<b>4</b>
LIFETIME FRAME WARRANTY.....	4
EXTENDED WARRANTY OF UP TO 5 YEARS ON BH MOTORS.....	5
EXTENDED WARRANTY FOR BH BATTERIES.....	5
REGISTERING EXTENDED WARRANTIES .....	6
WARRANTY OF PARTS OF THE ELECTRICAL ASSISTANCE SYSTEM.....	6
SUBMITTING A WARRANTY CLAIM.....	6
CONDITIONS THAT MAY VOID THE WARRANTY OF ELECTRICAL COMPONENTS.....	6
<b>03 MAINTENANCE</b> .....	<b>7</b>
INSPECT THE BICYCLE BEFORE USE .....	7
KEEP THE BICYCLE CLEAN.....	7
KEEP THE TRANSMISSION LUBRICATED AT ALL TIMES .....	7
PART MAINTENANCE .....	7
SPARE PARTS .....	8
AFTER A FALL, BLOW OR IMPACT.....	9
<b>04 WARNINGS ON USE</b> .....	<b>9</b>
MAXIMUM TYRE SIZE.....	9
MINIMUM AND MAXIMUM INSERTION LENGTH OF THE SEAT POST.....	9
MAXIMUM FORK LENGTH (AXLE-TO-CROWN).....	9
MAXIMUM NUMBER OF STEERING SPACERS .....	9
POSITION OF THE SPINDLE INSIDE THE FORK TUBE .....	9
INTENDED USE .....	9
<b>05 WARNINGS ON USE OF THE ELECTRICAL ASSISTANCE SYSTEM</b> .....	<b>10</b>
CARE AND INSTRUCTIONS FOR USE OF THE ELECTRICAL COMPONENTS AND BATTERIES .....	10
RECOMMENDATIONS TO MAXIMISE THE BATTERY LIFE .....	10
WARNINGS ON THE USE OF BATTERIES .....	10
UNSUITABLE CHARGING AND DISCHARGING ENVIRONMENTS AND SOLUTIONS.....	10
RECYCLING.....	10
MOTOR .....	10
<b>06 PEDAL ASSISTANCE SYSTEM OPERATION</b> .....	<b>11</b>
COMPONENTS OF THE PEDAL ASSISTANCE SYSTEM .....	11
PEDAL ASSISTANCE SYSTEM.....	11
PARTS OF THE CONTROL PANEL.....	11
SWITCHING THE PEDAL ASSISTANCE SYSTEM ON AND OFF.....	11
SELECTING THE PEDAL ASSISTANCE MODE.....	12
ASSISTANCE LEVELS .....	12
WALK ASSIST MODE .....	12
START OF PEDALLING.....	12
DISPLAYING THE BATTERY CHARGE LEVEL.....	13
DISPLAYING THE XPRO BATTERY CHARGE LEVEL.....	13

BATTERY AND CHARGER.....	13
BATTERY CHARGE .....	14
XPRO BATTERY .....	15
XPRO BOTTLE HOLDER.....	15
ENERGY SAVING MODES .....	15
APP BH BIKES ICONNECT .....	16
OPERATION WITH THE GARMIN DEVICE .....	17
ERROR CODES .....	17

<b>07 SIZES AND DIMENSIONS</b> .....	<b>18</b>
--------------------------------------	-----------

<b>08 TECHNICAL SPECIFICATIONS</b> .....	<b>19</b>
--	-----------

<b>09 ASSEMBLY AND SPARE PARTS</b> .....	<b>21</b>
DIMENSIONS OF THE STEERING TUBE.....	21
HEADSET ASSEMBLY.....	21
BH LITE AHEAD / AERO ACR STEM .....	22
BH LITE AHEAD / AERO ACR STEM .....	23
SADDLE SEAT POST ASSEMBLY.....	24
HANGER.....	24
DI2 BATTERY.....	24
FRONT DERAILLEUR BRACKET .....	25
MOTOR .....	25
CHARGING PORT.....	26
PLUGS XPRO .....	26
SPEED SENSOR .....	26
XPRO BOTTLE HOLDER .....	27
BATTERY HOLDER.....	27
CABLING OF THE MECHANICAL PARTS .....	28
CABLING OF THE ELECTRICAL SYSTEM'S PARTS.....	29
WIRING DIAGRAM OF THE ELECTRICAL SYSTEM'S PARTS.....	30

<b>10 DECLARATION OF CONFORMITY</b> .....	<b>31</b>
---	-----------

<b>11 HELP AND ADDITIONAL RESOURCES</b> .....	<b>31</b>
---	-----------

# 01 INTRODUCTION

This user manual contains important information for proper use and maintenance of the bicycle. In particular, this document contains specific information about the **IAEROLIGHT (EC195 / EC185 / EC175)**. Please read the entire manual carefully. The user manuals of all BH models can be consulted on the website at the following address:

<https://www.bhbikes.com/manuals>

Keep in mind that the manuals on the BH BIKES website are updated on a regular basis. Make sure you have downloaded the latest version from the website. You can check the version on the front page.

This document contains additional information to the general user manual, available at:

[https://www.bhbikes.com/es\\_ES/quienes-somos/manuales-descargas](https://www.bhbikes.com/es_ES/quienes-somos/manuales-descargas)

You can check the characteristics, recommendations and warranties of third-party parts on their corresponding official websites.

## SYMBOLS

This document contains different icons that refer to use, maintenance and assembly warnings. Carefully read the meaning of each one to prevent improper handling or hazardous situations that may result in serious personal injuries or fatal accidents.

### SAFETY



**DANGER:** refers to a hazardous situation that, if not avoided, will lead to serious injuries or even a fatal accident.



**WARNING:** refers to a hazardous situation that, if not avoided, could lead to serious injuries or even a fatal accident.



**ATTENTION:** refers to a hazardous situation that, if not avoided, could cause minor or moderate injuries.



**RISK OF ELECTRIC SHOCK:** refers to a hazardous situation that, if not avoided, could cause serious injuries due to electric shock or even death.



**RISK OF SHORT CIRCUIT:** refers to a hazardous situation that, if not avoided, could cause short circuits in the electrical components. Short circuits may cause damage to the electrical components and fire.

### TOOLS



**FLAT WRENCH**



**ALLEN KEY**



**TORX KEY**



**PHILLIPS SCREWDRIVER**



10Nm

**TIGHTENING TORQUES:** on one side of each tool symbol, the tightening torque will be indicated in newton metre.

### TYPE OF ASSEMBLY COMPOUND



**OIL:** light lubrication for elements such as chains and cables.



**GREASE:** assembly grease.



**CARBON PASTE:** assembly paste used to increase the friction of the carbon elements.



**ADHESIVE:** use medium strength thread lock.



Adhesive is used to fasten bolts and make sure that they do not come loose due to vibrations when using the bicycle. Add a drop of thread lock to the tip of the screw thread in all cases. Never apply more than one drop around the thread, since this will make it very hard to remove the bolt.



## 02 BH WARRANTY

BH BIKES undertakes to offer long-lasting bicycles, in compliance with the highest standards of quality. Therefore, in addition to the statutory warranty, BH BIKES offers an additional coverage and warranty. This section defines the different types of warranty and the process that must be followed to register for the additional "LifeTime Frame" warranty.

### STATUTORY WARRANTY

The statutory warranty covers the original purchaser in the event of manufacturing defects and/or non-conformities. This warranty applies to frames and components manufactured by BH BIKES. The warranty period will be established according to the current laws of the country where the bicycle was purchased, and will start on the date of purchase. During this period, the holder of the warranty will be entitled to have all manufacturing defects repaired or replaced free of charge, including the reimbursement of transport expenses and any losses caused as a result of this. Different conditions must be met in order to be covered by the warranty:

- This warranty does not affect the consumer's applicable rights, according to the current laws in each country.
- Faulty bicycles or parts will be covered by warranty upon the decision of our Technical Service.
- The warranty does not include the replacement of parts prone to wear and arising from normal use of the bicycle.
- The warranty does not cover defects or broken parts due to improper use of the bicycle, use for competitions, mounting of non-original accessories or improper handling and incorrect maintenance work.
- The warranty does not apply if the inspection before delivery and the corresponding inspection intervals included in this document have not been carried out, observed, documented as required and stamped by an authorised BH dealer.
- Should the repair not be satisfactory and not ensure that the optimum conditions are met according to the intended use, the holder of the warranty will be entitled to request the replacement of the purchased item or faulty part with one of identical characteristics, or to receive a refund of the amount paid for the damaged item or part.
- The warranty period will be interrupted during the repairs or, in the event of replaced items or components, it will be renewed.
- Any claim against this warranty shall expire six months after the end of the warranty validity period.
- All warranty claims must be processed by an authorised dealer.
- Geographical scope: refer to the User Manual or [www. BHbikes.com](http://www.BHbikes.com)

Visit the following link to read the terms and conditions:

[https://www.bhbikes.com/es\\_ES/registro-garantia-vida-bh/registra-tu-bici-garantia-de-por-vida](https://www.bhbikes.com/es_ES/registro-garantia-vida-bh/registra-tu-bici-garantia-de-por-vida)

## LIFETIME FRAME WARRANTY

Through its authorised stores, BH Bikes provides the original buyer with a commercial policy to cover any manufacturing defects in frames for a period beyond that specified in the product's statutory warranty, pursuant to the following clauses:

1. **The LIFETIME warranty solely applies to BH frames and bikes that are sold through stores that are authorised by BHBIKES EUROPE S.L.**
  - The buyer must register the LIFETIME warranty online, with the information duly completed, within 30 calendar days of the purchase date, as it appears on the invoice issued by the authorised store.
  - This warranty cannot be transferred to subsequent buyers and it is cancelled when the bicycle is sold to a third party. Original buyer means the individual who registers the warranty at the time of the purchase; the commercial warranty cannot be transferred to third parties who are not the original buyer.
  - It shall be compulsory to have the bicycle serviced in an establishment that is authorised by BHBIKES EUROPE and according to the instructions in the user manual.
2. **The LIFETIME warranty does not cover:**
  - The rear swingarms of the double suspension models, fork, kids' bikes, defects and/or fading of the original paint, or rust caused by natural deterioration.
  - Defects or breakages resulting from an accident or improper and/or negligent use of the bicycle.
  - When components or accessories that are not intended for or are not compatible with the use for which the bicycle was designed have been installed.
  - Defects resulting from improper handling.
  - Scratches, discolouration, or stains caused by the use of abrasive fluids, sharp items, clamps and/or prolonged exposure to sunlight or other weather conditions.
  - Defects caused by the bicycle's normal wear and tear, including those due to material fatigue. Fatigue damage is a sign that the frame has been damaged by normal use, so it is the user's responsibility to regularly inspect the bicycle.
  - Improper use and/or maintenance of the product (carefully read the recommendations for use and cleaning).
  - Frames that have been used in competitions, demos or as rentals.

Read the full terms and conditions at:

[https://www.bhbikes.com/es\\_ES/registro-garantia-vida-bh/registra-tu-bici-garantia-de-por-vida](https://www.bhbikes.com/es_ES/registro-garantia-vida-bh/registra-tu-bici-garantia-de-por-vida)

## EXTENDED WARRANTY OF UP TO 5 YEARS ON BH MOTORS

Activating the LIFETIME FRAME extended warranty will automatically activate a 5-year extended warranty for all BH motors. Through its authorised stores, BH Bikes provides the original buyer with a commercial policy to cover any manufacturing defects in BH motors for a period beyond that specified in the product's statutory warranty, pursuant to the following clauses:

- The BH motor extended warranty solely applies to BH motors installed in BH bikes and sold through stores that are authorised by BHBIKES EUROPE S.L.**
  - The buyer must register the warranty online, with the information duly completed, within 30 calendar days of the purchase date, as it appears on the invoice issued by the authorised store, on which the bike's serial no. must be specified.
  - This warranty cannot be transferred to subsequent buyers and it is cancelled when the bicycle is sold to a third party. Original buyer means the individual who registers the warranty at the time of the purchase; the commercial warranty cannot be transferred to third parties who are not the original buyer.
  - It shall be compulsory to have the bicycle serviced in an establishment that is authorised by BHBIKES and according to the instructions in the user manual.
- The BH motor extended warranty shall not ever cover:**
  - Fading paintwork and a loss of original colour, or corrosion caused by normal wear and tear.
  - Defects or breakages resulting from an accident or improper and/or negligent use of the bicycle.
  - When components or accessories have been installed that are not intended for/compatible with the use for which the bicycle was designed, and when the motor has been tampered with and/or de-limited.
  - Defects resulting from improper handling.
  - Scratches, discolouration, or stains caused by the use of abrasive fluids, sharp items, clamps and/or prolonged exposure to sunlight or other weather conditions.
  - Improper use and/or maintenance of the product (carefully read the recommendations for use and cleaning).
  - Motors that have been used in competitions, demos or in rentals.
  - Motors mounted on bicycles of the MONTY range.

Read the full terms and conditions at:

[https://www.bhbikes.com/es\\_ES/registro-garantia-vida-bh/registra-tu-bici-garantia-de-por-vida](https://www.bhbikes.com/es_ES/registro-garantia-vida-bh/registra-tu-bici-garantia-de-por-vida)

## EXTENDED WARRANTY FOR BH BATTERIES

In a constant effort to improve our customer services on a daily basis, BH offers the best warranty conditions and the possibility of acquiring an extended warranty for its e-Bike range (an additional one or two years). Through its authorised stores, BH Bikes provides the original buyer with a commercial policy to cover any manufacturing defects in BH batteries for a period beyond that specified in the product's statutory warranty, pursuant to the following clauses:

- The BH battery extended warranty solely applies to BH batteries installed in BH bikes and sold through stores that are authorised by BHBIKES EUROPE S.L:**
  - The buyer must register the warranty online, with the information duly completed, within 30 calendar days of the purchase date, as it appears on the invoice issued by the authorised store, on which the bike's serial no. must be specified.
  - This warranty cannot be transferred to subsequent buyers and it is cancelled when the bicycle is sold to a third party. Original buyer means the individual who registers the warranty at the time of the purchase; the commercial warranty cannot be transferred to third parties who are not the original buyer.
  - It shall be compulsory to have the bicycle serviced in an establishment that is authorised by BHBIKES and according to the instructions in the user manual.
- The BH battery extended warranty shall not ever cover:**
  - Fading paintwork and a loss of original colour, or corrosion caused by normal wear and tear.
  - Defects or breakages resulting from an accident or improper and/or negligent use of the bicycle.
  - Deterioration or natural degradation due to age, even without use. Deterioration after 500 full charging and discharging cycles if it is below 30% of the nominal capacity (read the recommendations in the user manual carefully).
  - When components or accessories have been installed that are not intended for/compatible with the use for which the bicycle was designed.
  - Defects resulting from improper handling.
  - Scratches, discolouration, or stains caused by the use of abrasive fluids, sharp items, clamps and/or prolonged exposure to sunlight or other weather conditions.
  - Improper use and/or maintenance of the product (carefully read the recommendations for use and cleaning).
  - Batteries that have been used in competitions, demos or in rentals.
  - Auxiliary batteries (extenders).

Read the full terms and conditions at:

[https://www.bhbikes.com/es\\_ES/registro-garantia-vida-bh/extension-garantia-bateria](https://www.bhbikes.com/es_ES/registro-garantia-vida-bh/extension-garantia-bateria)

## REGISTERING EXTENDED WARRANTIES

You must register the bicycle within 30 days after purchase to enjoy the BH BIKES additional warranties. The process to activate the extended warranties is described below:

- **LIFETIME FRAME WARRANTY + 5 YEARS WARRANTY ON BH ENGINES**

You must register the bicycle on the BH BIKES website to enjoy the LIFETIME FRAME extended warranty:

[https://www.bhbikes.com/es\\_ES/registro-garantia-vida-bh/registra-tu-bici-garantia-de-por-vida](https://www.bhbikes.com/es_ES/registro-garantia-vida-bh/registra-tu-bici-garantia-de-por-vida)

Watch this video to find out what you need to do:

<https://youtu.be/47aLVgUI248>



- **EXTENDED WARRANTY FOR BH BATTERIES**

You must register the bicycle on the BH BIKES website to enjoy the BH BATTERY extended warranty:

[https://www.bhbikes.com/es\\_ES/registro-garantia-vida-bh/extension-garantia-bateria](https://www.bhbikes.com/es_ES/registro-garantia-vida-bh/extension-garantia-bateria)

Watch this video to find out what you need to do:

<https://youtu.be/sINzdFBygMM>



- ⚠ The serial number required to register the bicycle is located on the bottom of the bicycle, on the seat tube, above the bottom bracket:

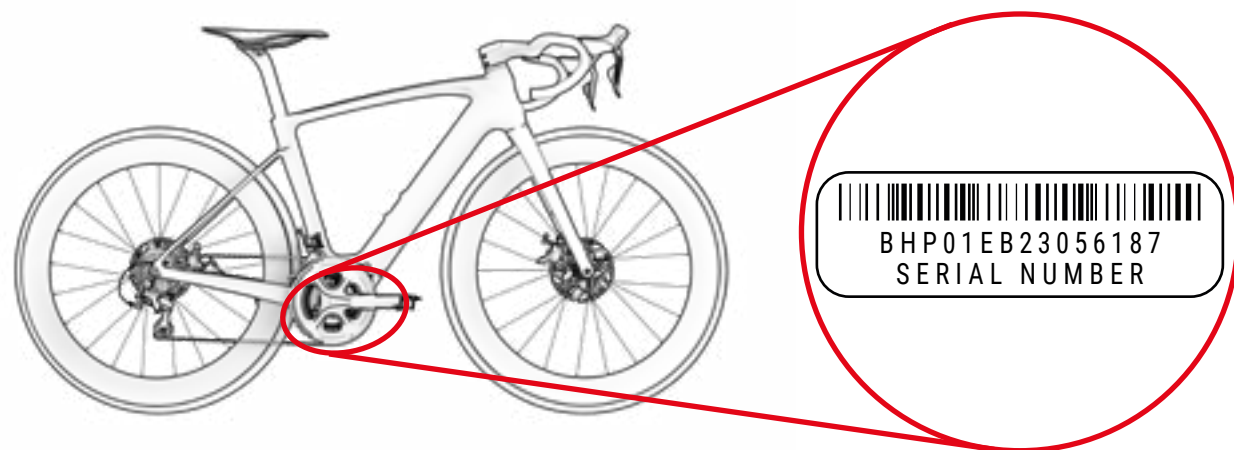

## WARRANTY OF PARTS OF THE ELECTRICAL ASSISTANCE SYSTEM

As in the case of BH BIKES frames and parts, all electrical components made exclusively for BH will be covered by the statutory warranty (BH motors feature an extended 5-year warranty after the LIFETIME FRAME warranty is activated). The warranty period will be established according to the current laws of the country where the bicycle was purchased, and will start on the date of purchase.

During this period, the holder of the warranty will be entitled to have all manufacturing defects repaired free of charge, including the reimbursement of transport expenses and any losses caused as a result of this. The terms and conditions are as described in the section "Statutory Warranty" and can be read at:

<https://www.bhbikes.com/manuals>

Under no circumstances shall the warranty cover the wear and natural ageing of batteries due to use, charging and storage. Likewise, the buyer must contact the original manufacturer to use the warranty of third-party parts.

## SUBMITTING A WARRANTY CLAIM

All warranty claims must be channelled through an official BH dealer. The dealer will analyse the claim to identify its scope and perform a preliminary assessment of the incident. The dealer will submit and process the claim directly with BH. Once BH has defined the corrective measures required, the dealer will send this information to the customer.

All claims must be processed by the official dealer from which you purchased your bicycle. If this is not possible, please contact us directly. We will help you find an authorised dealer near you:

[https://www.bhbikes.com/es\\_ES/quienes-somos/contacto](https://www.bhbikes.com/es_ES/quienes-somos/contacto)

## CONDITIONS THAT MAY VOID THE WARRANTY OF ELECTRICAL COMPONENTS

The BH battery and electrical components are covered by the statutory warranty, but the following requirements must be met:

- No electrical components must be removed or tampered with.
- The service life will vary according to the use, charging and storage conditions.
- Keep the battery charged at all times. Otherwise, the battery may deteriorate faster than normal.

## 03 MAINTENANCE

This user manual contains important information for IAEROLIGHT (EC195 / EC185 / EC175). Please read the entire manual carefully. The user manuals of all BH models can be consulted on the website at the following address:

<https://www.bhbikes.com/manuals>

This document contains additional information to the general user manual, available at:

<https://www.bhbikes.com/manuals>

You can check the characteristics and recommendations of third-party parts on their corresponding official websites.

### INSPECT THE BICYCLE BEFORE USE

Bicycles are inspected several times throughout the manufacturing process and then at the BH workshop during the final check. As the bicycle's operation may be affected during transport or third parties may have modified the bicycle before its sale, the following must be checked before each trip:

- **FRAME:** no cracks, damage or strange noises.
- **CHAIN:** it must be lubricated and the transmission system must not make any strange noises.
- **BRAKES:** the brakes must be working properly. When stopped, press the brake lever with enough strength and check that it does not touch the handlebars.
- **TYRES:** the pressure must be correct and there must be no cuts on the tread or on the sides. Also check that the wear level does not exceed the maximum recommended level.
- **WHEELS:** the wheels must rotate freely in order to check how they rotate. Also check the space between the brake lining and the rim, as well as the space between the frame and tyre.
- **STEERING:** the steering must turn smoothly and with no strange noises.
- **SWINGARM ROTATION POINTS:** when weight is exerted on the bicycle, the suspension must work as expected and with no strange noises. If it is not working properly or there is play between the moving parts, this might mean that the tightening torques are incorrect or that the bearings are worn.
- **BEARINGS:** the bearings must work properly and with no strange noises. The bearings are subject to wear and must be replaced to prevent damage to the components on which they are installed.
- **ELECTRICAL SYSTEM:** if the bicycle features an electrical system, check that it is functioning properly by ensuring that the electrical assistance mode is running and that all parts are functioning properly (motor, display, change of assistance mode and speed sensor). If there is no electrical assistance, check that all connections are correct and show no signs of damage.

 Do not ride your bicycle if it does not meet any of these points! A faulty bicycle may cause serious accidents! If you are unsure or have any queries, please contact your nearest BH workshop!

 Check the tightening torques to make sure that they are as described in the recommendations in the user manuals. Failure to observe these recommendations may result in accidents and even death.

 The effect of the ground and the forces exerted on the wheel subject the bicycle to a lot of stress. The different parts will be subject to fatigue and wear because of these dynamic loads. Check the bicycle at regular intervals to look for signs of wear, scratches, bent parts, wear on the finish or the formation of cracks. Parts may fail suddenly after their service life has expired. Take your bicycle to an authorised BH workshop regularly to have these parts replaced if needed.

### KEEP THE BICYCLE CLEAN

We recommend you follow these basic prevention measures to make sure that the bicycle is in perfect working order. Failure to observe these recommendations may lead to premature wear or even breakages in specific areas, such as gaskets or moving parts.

- Clean the dust and mud with a damp sponge and a gentle and neutral cleaning product.
- Plastic parts must only be washed with soapy water.
- Tyres can be washed with a sponge or brush and soapy water.
- After cleaning the bicycle, dry it by rubbing it firmly with a smooth cloth.
- After each cleaning, lubricate the transmission elements.

 Dirt may cause damage that can result in accidents or even death.

 Never use pressure washers or steam cleaners.

### KEEP THE TRANSMISSION LUBRICATED AT ALL TIMES

After washing the bicycle, the chain transmission's lubrication may have also been washed off. Inspect and lubricate the chain's links, if needed. Excess lubrication may attract more dirt, causing premature wear and incorrect functioning of the system.

 Never use pressure washers or steam cleaners.

### PART MAINTENANCE

The bicycle requires regular maintenance and a minimum number of regular inspections. The frequency of the maintenance operations depends on the type of vehicle (leisure, road or mountain bike), as well as the frequency and conditions of use.

## PART MAINTENANCE CALENDAR

Part	Action required	Before each outing	Monthly	Annually
Lighting	Functional check.			
Tyres	Pressure check.			
	Inspect the height of the profile and sides.			
Brakes (on the rim)	Check the lever travel, lining strength and rim position.			
	Brake test when stopped.			
	Clean the brake pads.			
Brake cables	Visual inspection.			
Brakes (disc brakes)	Change the brake fluid (DOT fluid).			
Suspension fork	Check the bolts and the corresponding tightening torque.			
	Change the oil and lubricate the elastomer.			
Saddle seat post with suspension	Maintenance.			
	Play check.			
Rims on rim brakes	Inspection and replacement, if needed, of the wall linings.	At the latest after the second part of the brake lining.		
Bottom bracket axle	Check the play.			
	Re-lubrication.			
Chain	Check and lubrication.			
	Check and replacement.	After 800 km.		
Chainsets	Check and tightening.			
Wheels / Spokes	Check wheel spin and spoke tension.			
Headset	Inspection of the headset.			
	Re-lubrication.			
Metal surfaces	Maintenance.	At least once every six months.		
Hubs	Bearing inspection.			
	Re-lubrication.			
Pedals	Bearing inspection.			
	Lubrication, cleaning the anchoring mechanism.			

Part	Action required	Before each outing	Monthly	Annually
Saddle seat post / Stem	Inspection of the fastening screws.			
Rear derailleur / Derailleur	Cleaning, lubrication.			
Quick-release mechanism / Thru-axle	Efficacy check.			
Nuts and bolts	Check and tightening.			
Spokes	Tension check.			
Stem / Saddle seat post	Removing and applying new assembly paste.			
Circuit / Brakes	Disassembly and greasing.			
	Check the connections.			
Components of the electrical assistance system	Check there is no dirt.			

 You do not need to take the bicycle to an expert if you are skilled, experienced and have the appropriate tools. Immediately implement the corrective measures if you detect problems. If you are unsure or have queries, please contact BH.

 The tasks described above must only be carried out by a trusted bike repair expert.

## SPARE PARTS

Original parts must be used to ensure the optimum performance of your bicycle and the utmost safety. Failure to use original parts may cause damage that is not covered by the warranty.

The most common spare parts are parts prone to wear. The most common ones are tyres, inner tubes, brake pads, disc brakes and brake pads, as well as rims, when these are part of the brake unit, headlights, position lights, batteries and accumulators.

- **TYRES:** Replace them with an equivalent type of tyre. Check the marking on the outside of the tyre (ETRTO standard). Keep in mind that using a tyre with a larger outer diameter than the recommended one may cause the tip of the foot to touch the front wheel or rear wheel guard when the handlebars turn. The cyclist may lose control of the bicycle and suffer an accident with serious consequences. This can also occur when the pedal chainset is replaced with a longer one.
- **INNER TUBES:** Replace them with a suitable type of inner tube, according to the type of tyre. Refer to the information on the outside of the inner tube (ETRTO standard).
- **DISC BRAKES AND BRAKE PADS:** Follow the instructions supplied by the manufacturer.
- **HEADLIGHTS AND POSITION LIGHTS:** Replace the bulb with one of the same type. Check the indication on the metal area.



- **CHAIN, COG AND CHAIN RINGS:** Follow the instructions supplied by the manufacturer.
- **BATTERIES AND ACCUMULATORS:** Change for the same type. Check the indication on the outer area.

**⚠** Remember that the failure to use original parts may cause damage that is not covered by the warranty.

## AFTER A FALL, BLOW OR IMPACT

If you suffer a fall, blow or impact, first make sure that you are okay to continue cycling. Do not use the bike if you are injured and ask for medical assistance if needed.

If you are okay to continue cycling, check the bicycle to make sure that it is in perfect working order:

- Check that the wheels are firmly secured and that the rims are in the centre of the frame and fork. Turn the wheels. If they cannot be centred in situ because the gap is too small, separate the brakes from the rim so it can move freely.

**⚠** In this case, keep in mind that the braking efficacy will be less.

- Check whether the handlebars or the front of the frame are twisted or broken. Check that the front is firmly seated on the fork, holding the front wheel firmly between your legs and trying to twist the handlebars with respect to the front wheel.
- Check that the chain is fitted correctly. If the bicycle fell onto the transmission side, check that it is working properly. Ask for help to place the bicycle on its saddle and change gears. When the chain fits on the largest cog, check the distance between the gear and the spokes. If the gear or bracket are bent, the first one may become stuck on the spokes - Danger of falling! The gear, rear wheel or frame may be damaged. Check the derailleur. If it has shifted, the chain may come off the gear. The bicycle's transmission will become less effective (also refer to the "Traction" section).
- Check the saddle, upper tube or the bottom bracket box to make sure that there are no defects.
- Lift the bicycle slightly and let it drop onto the ground. If there are any noises, inspect the bicycle for any loose bolts.
- Inspect the entire bicycle again to check for bent areas, worn finish or cracks.
- Ride again carefully if no problems have been detected during the inspection. Do not brake or accelerate suddenly or pedal when going uphill. If you are unsure, wait for a car to pick you up instead of risking an accident. Once home, you should inspect the bicycle carefully again. If you are still unsure or have any queries, please contact your nearest BH workshop!

**⚠** Bent aluminium parts must not be straightened, i.e., they must not be repaired. Even afterwards, there is a high risk of breakage, especially in regards to the fork, handlebars, front part, chainsets and pedals. Replace them for greater safety.

## **04** WARNINGS ON USE

### MAXIMUM TYRE SIZE

If you install a tyre of a different size on your bicycle, check and make sure that there are at least 6 mm between the tyre and other parts of the frame and fork.

### MINIMUM AND MAXIMUM INSERTION LENGTH OF THE SEAT POST

Failure to observe the maximum and minimum seat post insertion dimensions indicated in this manual may cause a lever effect on the frame. The pressure exerted could damage the frame and cause serious accidents. The warranty does not cover the damage generated by failing to observe these indications.

### MAXIMUM FORK LENGTH (AXLE-TO-CROWN)

Observe the maximum length between the fork axle and the lower part of the steering tube (axle-to-crown). If this maximum length is not observed, the frame could be damaged due to withstanding a greater load than that for which it was designed and may cause serious accidents.

### MAXIMUM NUMBER OF STEERING SPACERS

This manual specifies the maximum number of steering spacers that can be fitted under the stem. If this maximum quantity is not observed, the materials could be damaged due to withstanding a greater load than that for which they were designed and may cause serious accidents.

### POSITION OF THE SPINDLE INSIDE THE FORK TUBE

No steering spacers must be fitted above the stem. Otherwise, the materials could be damaged due to withstanding a greater load than that for which they were designed and may cause serious accidents.

### INTENDED USE

Each bicycle has been designed according to a specific intended use. The models described in this manual meet the requirements associated with their intended use:

This is a set of conditions for the operation of the bicycle that provides for its use on asphalt roads. In addition, the wheels must be kept in contact with the running surface at all times

## 05 WARNINGS ON USE OF THE ELECTRICAL ASSISTANCE SYSTEM

### CARE AND INSTRUCTIONS FOR USE OF THE ELECTRICAL COMPONENTS AND BATTERIES

All BH products and parts have been designed to withstand splashed liquids and rain. However, some practices may cause damage to the parts and short circuits. Do not do the following:

- Wash the bicycle with pressure devices.
- Use the bicycle under adverse weather conditions.
- Transport the bicycle on the outside of a vehicle when it is raining.
- Expose the batteries to very high temperatures. If the temperature exceeds 70°C, this could cause leaks and there could be a risk of fire.
- Fail to observe the working temperature, storage and charging range of the bicycle.

### RECOMMENDATIONS TO MAXIMISE THE BATTERY LIFE

We recommend the following to maximise the battery life:

- Charge it on a flat and stable surface.
- Make sure that it is not exposed to direct sunlight.
- Make sure that there are no children or pets near.
- Make sure that there is no rain or dampness.
- The place must be well ventilated and dry.
- The temperature must be between 15-25°C.
- Do not use the battery with a charge of less than 10%. The useful life of the cells may be affected below this charge level.

 Any unauthorised handling of the electrical system's components may cause serious accidents and will void the warranty.

### WARNINGS ON THE USE OF BATTERIES

Improper use of the batteries may cause damage and serious accidents. Follow these recommendations to prevent this:

- Always use the original battery charger.
- Never leave the battery near sources of heat.
- Do not heat the battery or throw it into a fire.

- Prevent the battery connections from coming into contact with metal objects.
- Do not submerge the battery in water and prevent splashes and dampness.
- Do not hit or drill holes into the battery.
- Make sure that the battery liquid does not touch your hands or eyes in the event of a leak.
- Do not use it if there are external signs of damage.
- Only clean the battery with a dry or damp cloth.

### UNSUITABLE CHARGING AND DISCHARGING ENVIRONMENTS AND SOLUTIONS

The hot and cold environments described below may lead to charging entering standby or sleep mode without fully charging the battery.

- **Winter discharging sleep mode or DUT (Discharge Under Temperature):** Battery discharging will enter the deep sleep mode if the temperature is below -20°C, stopping the pedal assistance system from working and protecting the battery. In such cases, sleep mode will automatically be disabled when the battery exceeds -20°C.
- **Winter charging sleep mode or CUT (Charge Under Temperature):** Battery charging will enter sleep mode if the temperature is below 0°C. If charging starts and the temperature falls below this level due to night cooling or other factors, charging will stop and sleep mode will be activated to protect the battery. In such cases, sleep mode will automatically be disabled when the battery exceeds 0°C.
- **Noise on televisions/radios/computers:** Charging near televisions, radios or similar devices may cause static electricity, flickering images and other interference. If this happens, recharge somewhere that is away from the television or radio (e.g. in another room).

### RECYCLING

Ion-lithium batteries can be recycled but they may harm the environment if they are not managed properly after the end of their service life. Follow these steps after the end of their service life:

- Classify and recycle each electrical component in a place prepared for the sustainable recycling of such parts.
- Check and make sure that the applicable regulations of your country are observed with regards to batteries.

### MOTOR

The DC motor is located on the bottom bracket axle. The motor's service life depends on its use, as in the case of any other part of the bicycle. Under normal conditions, the motor can last for 10 to 20 years, or up to 100,000 km.

## 06 PEDAL ASSISTANCE SYSTEM OPERATION

### COMPONENTS OF THE PEDAL ASSISTANCE SYSTEM

The BH Bikes pedal assistance system is made up of the following components:

- **A. A motor**, which drives the bicycle.
- **B. A control panel** which, among other things, allows you to select the assistance mode.
- **C. A battery**, which powers the motor.
- **D. A torque sensor**, which reads the force applied to the pedal by the user.
- **E. A display** (CORE DISPLAY), which shows relevant system information.

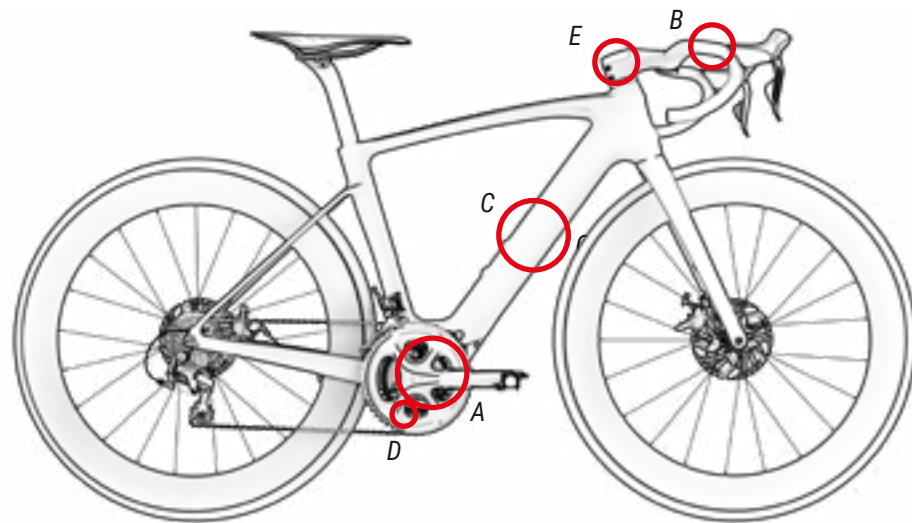

### PEDAL ASSISTANCE SYSTEM

The pedal assistance system is designed to provide the optimal amount of assisted power. It provides assistance within a standard range, based on factors such as the pedalling force, the speed of the bicycle and the transmission.

The system does not provide assistance in the following situations:

- If the control panel is off.
- When travelling at 25 km/h or faster.
- If you are not pedalling and the throttle function is released at 6 km/h.
- If there is no remaining battery capacity.
- If the assistance mode selected is 0% assistance.

## PARTS OF THE CONTROL PANEL

EC195 / EC185 / EC175

The Core display is made up of a ring with 12 LEDs and a button inside the ring, used as the control panel:

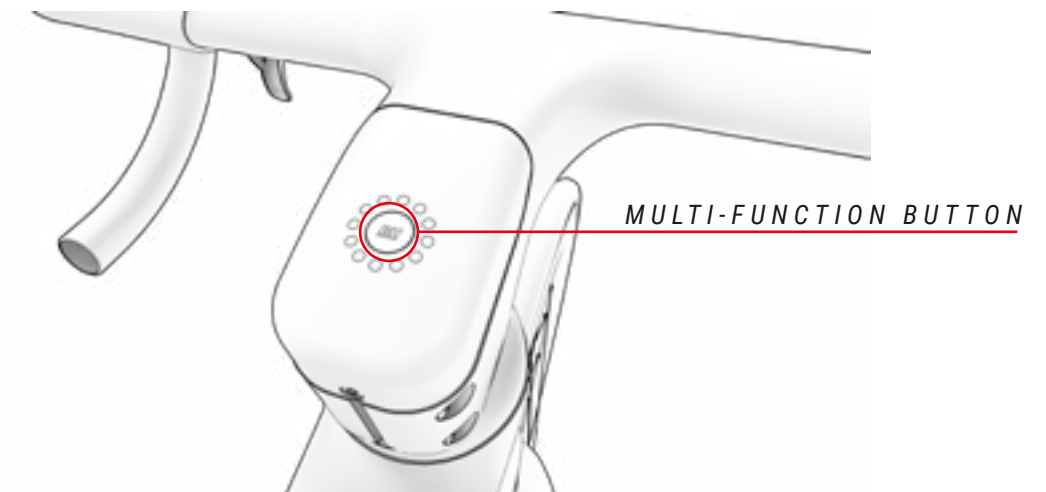

### SWITCHING THE PEDAL ASSISTANCE SYSTEM ON AND OFF

EC195 / EC185 / EC175

The pedal assistance system is activated from the Core display. It is located on the bicycle's stem. Press the power button to start the system. The Core display will be lit, showing a blue animation moving counterclockwise. The current pedal assistance mode will be shown next.

To disconnect the pedal assistance system, press and hold the multi-function button for 3 seconds. The screen will turn off and the system will shut down.



## SELECTING THE PEDAL ASSISTANCE MODE

EC195 / EC185 / EC175

The system features the following pedalling assistance modes:

- **Boost:** Identified by the colour **Red**. Use when you want to get peak power from the system.
- **Trail:** Identified by the colour **Orange**. Use when climbing difficult terrains.
- **Eco:** Identified by the colour **Green**. Use when you want to travel as far as possible.
- **No assist:** Identified by the colour **White**. Use when you want to travel without assisted power. You can continue to use the other functions of the control panel.

To scroll through the different assistance modes, the user must press the multi-function button once to increase the level of assistance and twice to decrease it.

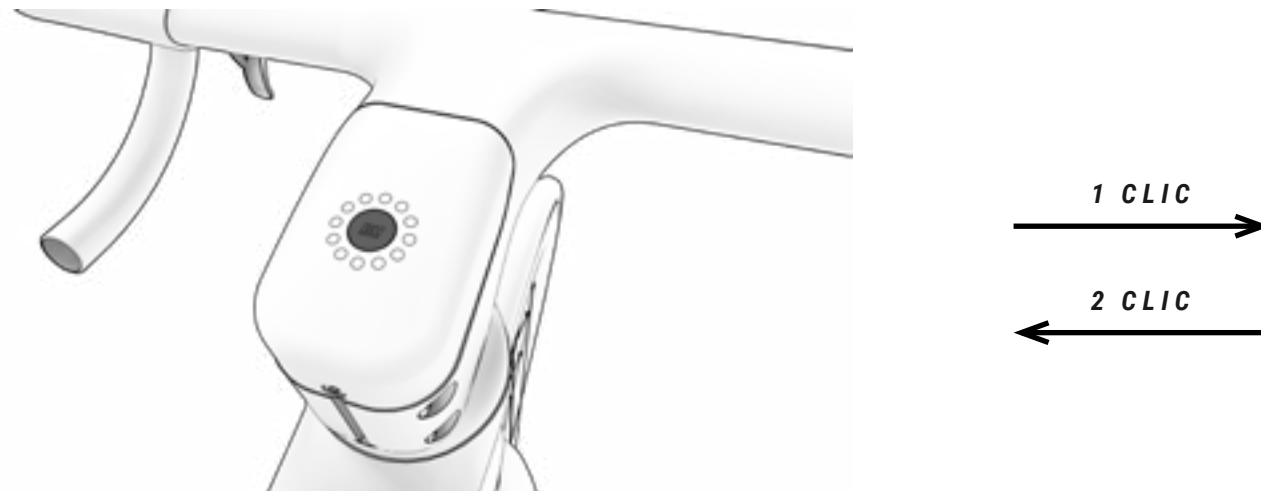

## ASSISTANCE LEVELS

In order to preserve the health of the bicycle components, the assistance protocols using the combination of the internal battery will be as follows:

Internal battery charged above 5%: 100% of the maximum assistance level is available.

Internal battery charged between 1 and 5%: No assistance. Energy will only be available for turning on the lights and the display.

Internal battery below 1%: Off. The battery will not be able to turn on the display.

XPro battery: The XPro battery will provide 100% assistance regardless of its charge level.

## WALK ASSIST MODE

EC195 / EC185 / EC175

The walk assist mode helps the user to transport the bike by foot. To activate this mode, press and hold the + button on the control panel (it doesn't matter which assistance mode is selected when the button is pressed). The LEDs on the CORE DISPLAY will flash blue, indicating that this mode has been activated. Release the button to exit this mode.

## START OF PEDALLING

Before resting your feet on the pedals, you must sit on the saddle and hold the handlebars firmly. Special care should be taken if you start pedalling when using a high assistance mode (TRAIL and BOOST modes), as the motor will respond with maximum thrust and you may lose control. To facilitate acceleration, the motor provides an additional initial thrust as soon as you start pedalling. Therefore, minimal force is required to put the bicycle in motion, helping you to join the traffic quickly and safely.

- ⚠ Start pedalling with a short gear ratio (higher gears) and low assistance mode (ECO mode). As well as providing greater control and safety on the bicycle, it requires less energy consumption and, therefore, ensures a longer range. Starting to pedal with a higher assistance mode (TRAIL and BOOST modes) may put the user at risk.
- ⚠ When the user pushes the bike while walking alongside it, they must make sure that the system is disconnected.

## DISPLAYING THE BATTERY CHARGE LEVEL

A 100% charge can provide a range of up to 165 km. The battery charge level can be displayed in different ways. The battery charge level indicator shows the estimated remaining battery capacity in all cases:

- **Garmin devices:** Garmin devices also display the battery level on their interface:



The battery charge level will be shown with the ring of LEDs. The current battery level can be interpreted according to the number of LEDs that are lit. Keep in mind that the colour shown only refers to the current assistance mode.

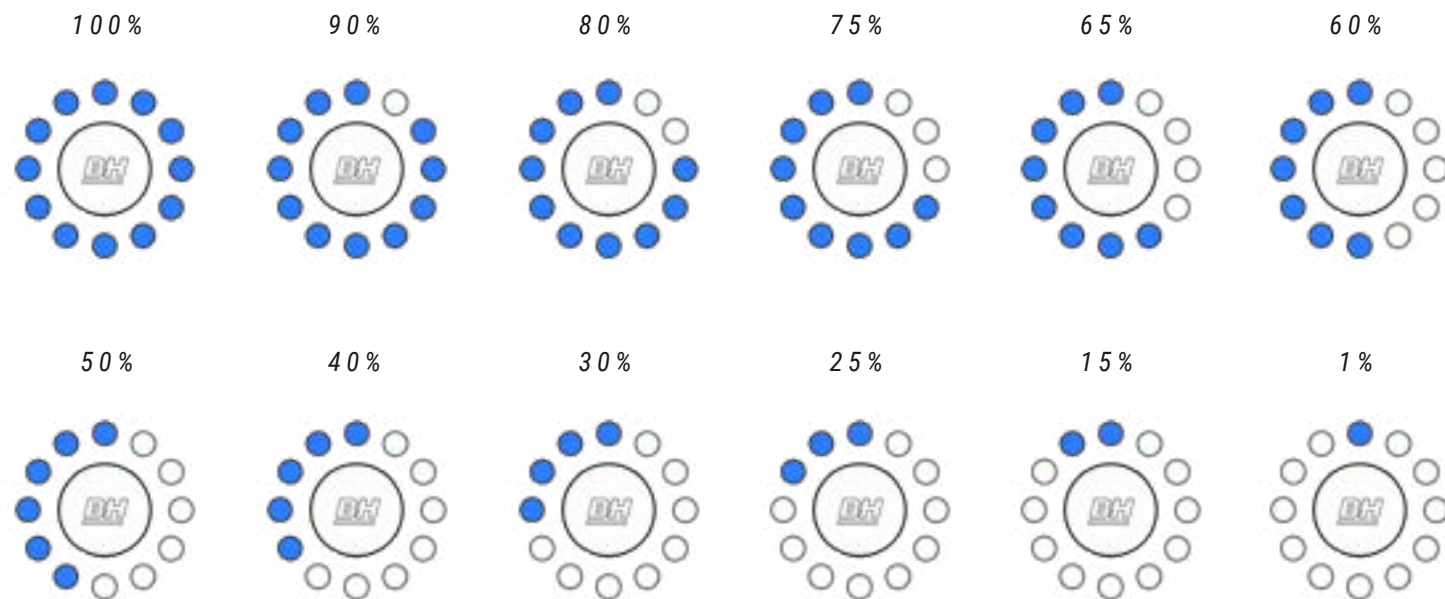

## DISPLAYING THE XPRO BATTERY CHARGE LEVEL

The XPRO external battery boosts the standard 160 km range up to 220 km. By pressing the XPRO battery button, a ring will be lit around the button. The colour of this ring indicates the XPRO battery charge level. Green 100-75%, blue 75-50%, yellow 50-25%, red 25-10% and flashing red 10-0%.

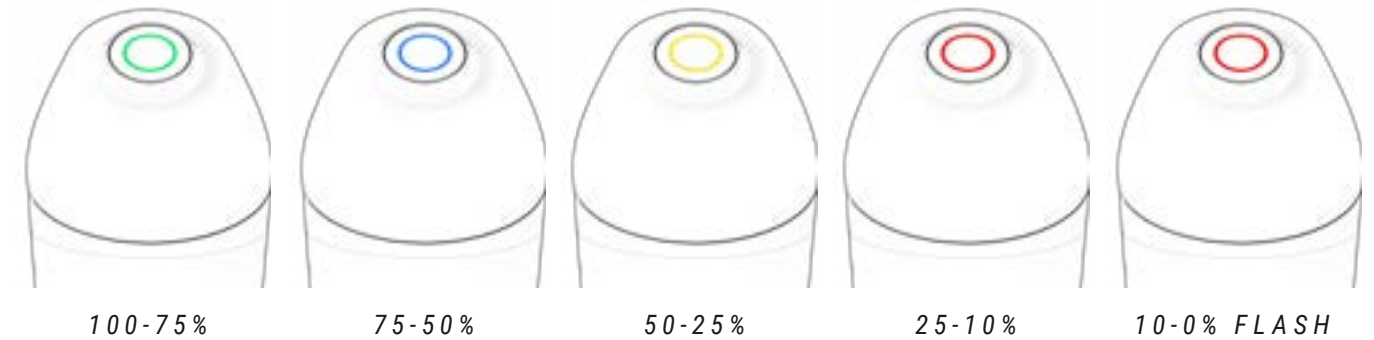

In models equipped with the Core display, the XPRO battery charge level will be shown with the ring of LEDs. The capacity of the XPRO battery will be added to the capacity of the bicycle's internal battery and the display will show the total charge of both batteries as follows:

If both batteries have a full charge (100%), the display will show 100% charge.

100% INTERNAL BATTERY: 410 WH  
100%

100% INTERNAL BATTERY + XPRO: 410 WH + 180 WH  
100%



## BATTERY AND CHARGER

The battery that your BH bike is equipped with contains lithium-ion cells and is the most advanced technology available in terms of energy density (energy stored per kilogram of weight and per cm<sup>3</sup> of volume).

Lithium-ion batteries have the following characteristics:

- Their performance decreases in extremely hot or cold environments.
- An additional characteristic of BH's lithium-ion batteries is that they have no "memory effect", and are not affected by incomplete discharging.
- They lose their charge naturally and gradually with use. The battery can be fully discharged (100%) approximately 500 times, with maximum battery deterioration of 20%. In the case of partial discharges, only the discharged part is counted. For example, if you charge the battery every time its charge level falls by 25%, you will be able to charge it to 100% of its initial capacity 2,000 times. In short, the guaranteed durability of the battery with maximum degradation of 20% is at least 20,000 km.

## BATTERY CHARGE

Due to its advanced lithium-ion technology, there is no need to wait for the battery to completely discharge before connecting it to the charger. Likewise, it is also not necessary to charge it to 100% before using it again. But bear in mind that, in order to achieve a maximum operating range, a full charge is recommended.

- 1. TURN ON THE DISPLAY. IT WILL NOT CHARGE IF THE DISPLAY IS OFF.**      **2. OPEN THE COVER OF THE CHARGING PORT ON THE LOWER LEFT SIDE OF THE FRAME.**



- 3. CONNECT THE BATTERY FIRST AND THEN PLUG INTO THE POWER SOCKET.**

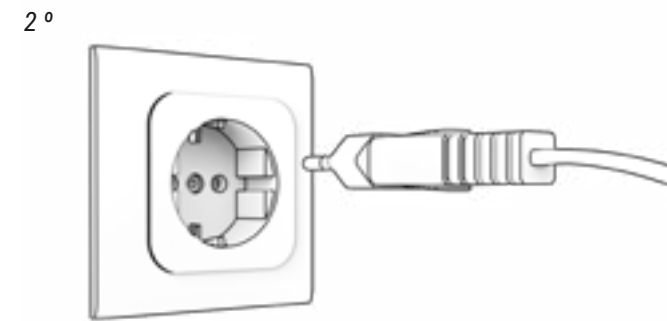

- 4. VIEW THE STATE OF CHARGE AND ERRORS.**



**100% CHARGED**  
**STANDBY (FLASH)**

**CHARGING**  
**CHARGING PROBLEM (FLASH)**

- 5. ALWAYS DISCONNECT THE BATTERY CHARGER FIRST AND THEN REMOVE THE PLUG FROM THE POWER SOCKET.**

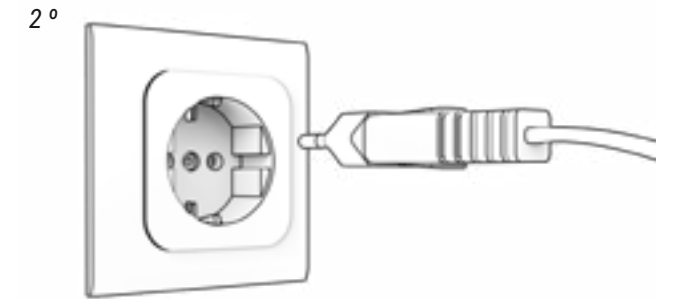
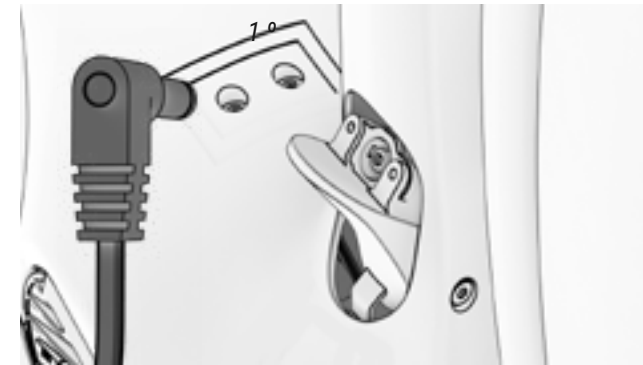

- 6. CAREFULLY CLOSE THE CHARGING PORT COVER, MAKING SURE NO DIRT OR WATER ENTERS.**



- 7. THE XPRO BATTERY WILL BE CHARGED IF IT IS IN THE BOTTLE HOLDER AND THE BICYCLE IS CHARGING, WITH THE DISPLAY ON.**

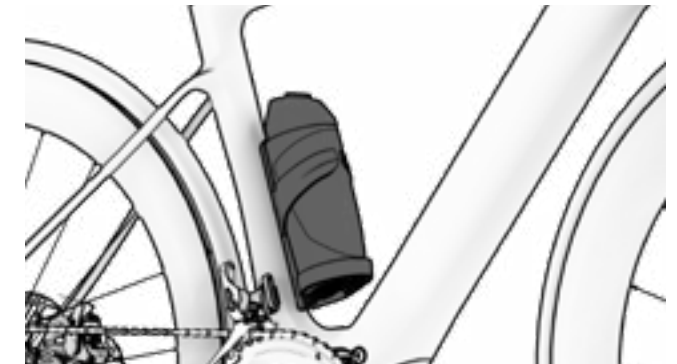

- Never charge or use a damaged battery.
- Be careful not to touch the charger during the charging process. It may be hot, especially in high ambient temperatures.
- If a fault occurs while the battery is being charged, remove the charger's power plug from the socket and wait for the battery to cool down.
- Never touch the power plug, charging plug or contacts with wet hands.
- Make sure that there is no foreign matter on the battery's contacts before placing it on the bicycle.
- Do not connect the charger's power plug to the battery or bicycle's charging port if it is wet or damp. Make sure that you only connect the power plug when the battery or bicycle's charging port is completely dry.
- Do not apply excessive force on the power plug or pull the cable with the power plug connected to the battery.
- Turn off the pedal assistance system before removing the battery from the bicycle.
- Use both hands to remove the battery, taking special care not to drop it. Dropping the battery on your foot could cause injury and may damage the battery.

## XPRO BATTERY

The Xpro additional battery or extender allows you to extend the bike's range. This is a bottle-shaped external 180 Wh battery that fits a specific bottle holder, which must be properly installed and connected to the system by an authorised store. When the bottle holder has been installed, the external battery is connected to the system by simply inserting it into the bottle holder. In other words, this is a Plug&Ride battery that requires no additional connection or work to operate.



## XPRO BOTTLE HOLDER

The bottle holder features a waterproof connector, guaranteeing the protection of the system. Therefore, the user can fit a conventional water bottle in the bottle holder or leave it empty.

## ENERGY SAVING MODES

The battery has been designed to ensure a long service life. This is possible thanks to the energy saving modes that prevent inefficient battery consumption:

- **Transport mode:** In order to minimise internal consumption while transporting the bicycle from the factory to the store, the battery is in Transport mode. The user can finally exit this Transport mode by charging the battery to 100% before its first use.

If the battery does not charge fully, the Transport mode will not deactivate, repeatedly entering this mode quickly for its protection. Remember to fully charge the battery to finally deactivate the Transport mode.

- **Standby mode:** In order to minimise internal consumption, the battery automatically switches to Standby mode. This happens automatically when the system detects no charging, no discharging and no communication with the battery for a period of 10 minutes. So, for example, this mode will automatically turn off the control panel after 10 minutes without use, if the user has left it on after parking.

The user can exit this Standby mode by simply turning on the bicycle's control panel.

- **Deep Sleep mode:** In order to protect the battery during long periods of inactivity or storage (for example, during the winter), the battery automatically switches to Deep Sleep mode. This happens automatically when any of the following situations occur:
  - If the charge level of the battery is below 1%, the battery goes into Deep Sleep mode when the battery has continuously been in Standby mode for 10 minutes.
  - If the charge level of the battery is below 10%, the battery goes into Deep Sleep mode when the battery has continuously been in Standby mode for 48 hours.
  - If the charge level of the battery is below 40%: Deep Sleep mode is activated when the battery has continuously been in Standby mode for 14 days.
  - If the charge level of the battery is below 80%: Deep Sleep mode is activated when the battery has continuously been in Standby mode for 30 days.

The user can exit this Deep Sleep mode by pressing and holding the battery's SOC button (which checks the charge level) for 5 seconds or by starting to charge the battery with the charger. All LEDs will flash twice in the Standby mode and once in the Deep Sleep mode.

# APP BH BIKES ICONNECT

The BH Bikes iConnect app can be used to customise the configuration of the pedal assistance system:

- Change the assistance level colours.
- Changing the assistance (0-100%) and acceleration parameters for each level of assistance.
- 

**Download the app (available for IOS and Android) and follow these steps to link your bicycle to the app:**

**App Store:** <https://apps.apple.com/es/app/bh-bikes-icconnect/id1494346206>



**Google Play:** <https://play.google.com/store/apps/details?id=com.bh.ebikelight>



The general operation is described below:

**1. TAP ON "SEARCH" TO SEARCH FOR AVAILABLE DEVICES.**



**2. TAP ON UPLOAD TO LOAD THE BICYCLE'S CONFIGURATION TO THE APP.**

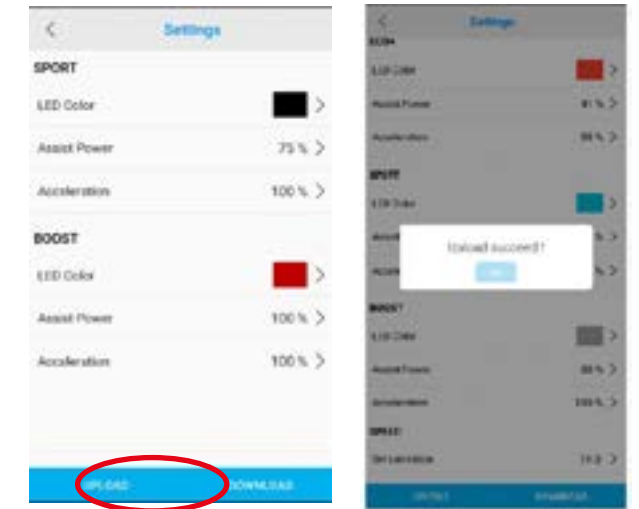

**Watch the video from the following link to learn how the app works:**

<https://youtu.be/k4sOiG0cX3U>



**3. CHANGE THE COLOUR, ASSISTANCE AND ACCELERATION OF EACH MODE.**



**4. TAP ON "DOWNLOAD" TO SEND THE DATA TO THE BICYCLE.**





## OPERATION WITH THE GARMIN DEVICE

The ANT+ connection to a Garmin device grants you access to additional assistance display and control functions. The Heart Rate strap connects via the Garmin device. The steps that must be followed to connect iRemote to the Garmin device are described below. The image in the sixth step shows that the Garmin device can be used to check the bicycle's battery status and to select the desired pedal assistance level.

1. TAP ON "ADD SENSOR".

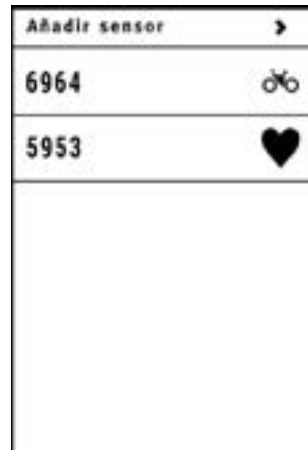

2. TAP ON "E-BIKE".



3. PAIR WITH YOUR GARMIN DEVICE.

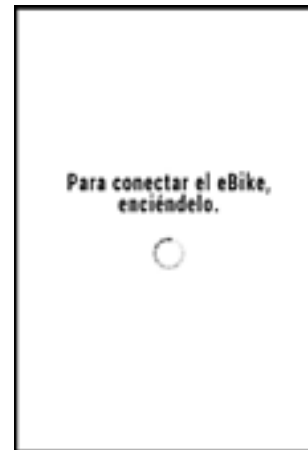

4. SELECT THE E-BIKE.

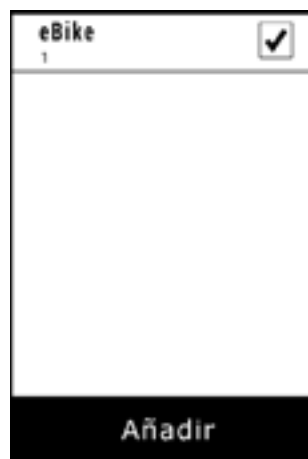

5. SELECT THE SENSOR YOU HAVE CREATED.



6. GARMIN CONNECTED.



## ERROR CODES

Errors will be shown on the display. Below are the errors and the actions that must be taken on the Core display.

The errors will be shown with the LEDs in models equipped with the Core display. The number of LEDs that are on or off will refer to a specific error. Below is a description of the possible problems:



### ERROR DESCRIPTION

No.	Code	Description	Action required
0		System Normal	
1		Overcurrent (excessive current)	Please check if the connector between the motor and controller is loose. If not, install a new controller!
2		Static current over limit	Please change the controller
3		Throttle or TMM Signal Abnormal	Please check if the connector between the TMM sensor and controller is loose. Also check that the magnet position is correct.
4		Incorrect motor phase	Please check the motor connector or controller.

## ERROR DESCRIPTIONS

No.	Code	Description	Action required
5		Motor Hall sensor error	Please check if the connector between the motor and controller is loose. Hall sensor inside of the motor is broken, replace the Hall sensor or install a new motor. Bad contact of the controller-motor cable, install a new controller.
8		Low Battery voltage	Change the battery or check the battery output
9		Motor stalled	Motor stops by accident; motor stalled.
10		Current over limit	Bad contact of the controller-motor connector if needed, install a new one.
11		Motor overheating alarm	If the temperature exceeds the setting, the current will start to gradually decrease
12		Motor overheating protection	Entering the temperature protection mode, no controller output
13		Communication error	<ol style="list-style-type: none"> <li>1. Communication line was loose, please check the communication cable and its connector</li> <li>2. The Controller's MCU is malfunctioning, change the controller.</li> <li>3. Short in the TMM wire, please disconnect the TMM sensor to check it.</li> <li>4. Short in the motor Hall wires, please disconnect the motor connector and check again,</li> <li>5. The motor power wires touched the Hall wires, causing damage and shorting the Hall wires.</li> <li>6. Display communication parts malfunctioning, please install a new display.</li> <li>7. Check the Display and CAN controller Communication line was loose (REVO ONLY)</li> </ol>
14		Foot error	Please remove your feet from the pedals and switch on again.
33		Fault_e_SpeedSensorNoInts	Switch the system off completely and then back on. If the problem persists, contact your e-bike dealer.

## 07 SIZES AND DIMENSIONS

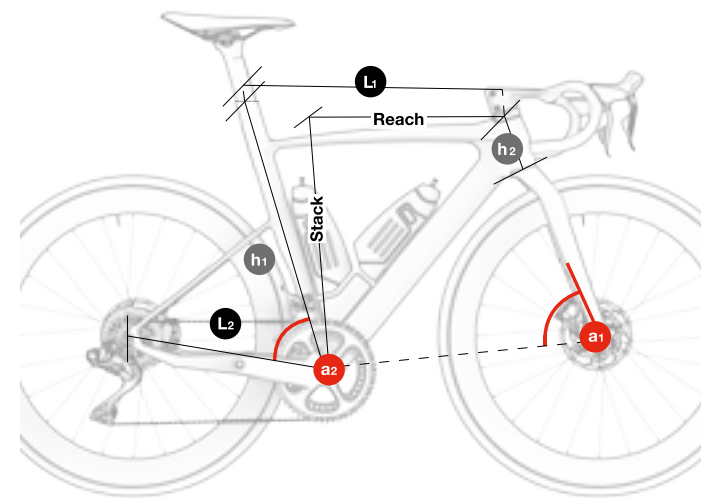

### ALL MODELS IAEROLIGHT

	h1	h2	L1	L2	a1	a2	Stack	Reach
SM	570	120	525	410	72.25°	74°	509	380
MD	585	135	542	410	72.75°	73.5°	524	387
LA	604	150	559	410	73°	73°	540	394

### MAXIMUM AND MINIMUM SEAT HEIGHT

Reference seat: **Prologo Dimension**

	h1	h3 MAX	h3 MIN
SM	570	773	693
MD	585	793	710
LA	604	810	730

**⚠** Always observe the specified maximum and minimum heights to ensure that the integrated seatpost clamping system functions correctly. Damage resulting from incorrect adjustment will not be covered by the warranty and could lead to serious accidents.

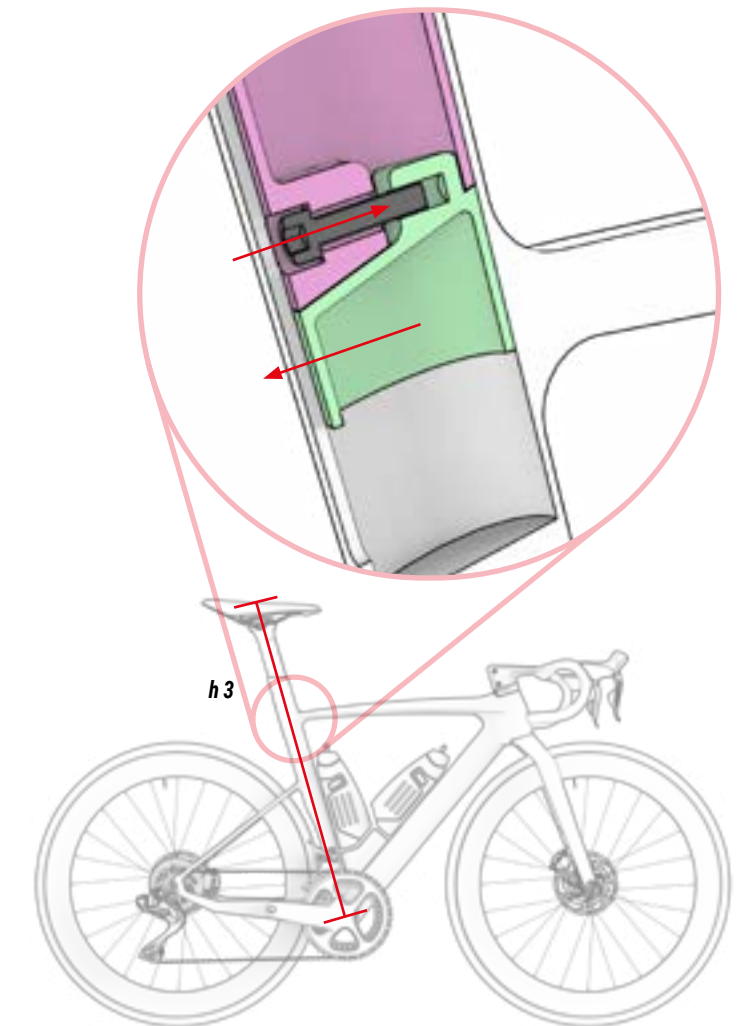

## 08 TECHNICAL SPECIFICATIONS

### TECHNICAL SPECIFICATIONS

Characteristics	Models	Specification
<b>Material</b>		
<b>Frame</b>	All	Carbon
<b>Fork</b>	All	Carbon Aero Flow
<b>Recommended use</b>	All	Road, Racing Aero
<b>Sizes</b>	All	SM, MD, LA
<b>Fork reach</b>	All	50 mm for SM, 45 mm for MD/LA
<b>Maximum steering spacer height</b>	All	2x15 + 1x10 mm (pre-cut as standard)
<b>Fork steering tube</b>	All	Full carbon 1.5", conical
<b>Compatible wheel size</b>	All	700C
<b>Maximum tyre width</b>	All	32 mm
<b>Bottom bracket</b>	All	BB386
<b>Bottom bracket box width</b>	All	86.5 mm
<b>Inner diameter of the bottom bracket box</b>	All	46 mm
<b>Standard front dropouts</b>	All	Thru-axle
<b>Front axle dimensions</b>	All	119 mm
<b>Front axle pitch thread</b>	All	12x1.0 mm
<b>Standard rear dropouts</b>	All	Thru-axle
<b>Rear axle dimensions</b>	All	158 mm
<b>Rear axle pitch thread</b>	All	12x1.0 mm
<b>Seat post</b>	All	Aerolight
<b>Seat post clamp</b>	All	Aerolight, built into the saddle tube
<b>Derailleur</b>	All	Carbon monocoque

Characteristics	Models	Specification
<b>Maximum large chain ring size</b>	All	50 teeth
<b>Minimum large chain ring size</b>	All	46 teeth
<b>Minimum small chain ring size</b>	All	34 teeth
<b>Maximum small chain ring size</b>	All	42 teeth
<b>Compatible with the triple chain ring</b>	All	No
<b>Brake type</b>	All	Disc
<b>Rear brake standard</b>	All	Post Mount
<b>Derailleur</b>	All	Removable Aerolight
<b>Compatibility with transmissions</b>	All	Sram, Shimano and Campagnolo EPS (non-mechanical)
<b>Front brake</b>	All	160 mm
<b>Rear brake</b>	All	160 mm
<b>Cabling</b>	All	Internal ACR system
<b>Bottle holder</b>	All	2
<b>Compatible with mudguard</b>	All	No
<b>Compatible with pannier rack</b>	All	No
<b>Compatible with child seat</b>	All	No
<b>Compatible with trailer</b>	All	No
<b>Potentiometer compatibility</b>	All	No
<b>Maximum recommended weight (cyclist+equipment+bags)</b>	All	165 kg

## BH-2EZMAG MOTOR SPECIFICATIONS

Characteristics	Specification
Rated power	250W
Voltage	36V
Type	Brushless DC
Assistance	Hasta 25km/h
Maximum torque	65Nm
Weight	2100g
Pedal assistance modes	6
Walk assist	Yes (by pressing and holding the + button)
Cadence range	130/min.
Sensors	Cadence / Torque / Speed
System technology	CAN bus

## BATTERY SPECIFICATIONS

Characteristics	Specification
Voltage	36V
Capacity	EC195: 410WH+180WH All other models: 410WH
Weight	410WH: 1610g y 180WH: 1000g
Cell pack	410+180WH: (10S2P+10S1P) y 410WH: 20 (10S2P)
Charge level	With battery inside the frame.
Dimensions	462x67x49mm
Connection	Cable connected to the motor and charging port.
Watertightness	IP65

## CHARGER SPECIFICATIONS

Characteristics	Specification
Input	100-240V. 50-60Hz. AC
Output	42V
Charging current	4A
Charging temperature range	0°C - 40°C
Display of the charging progress	With the LED built into the charger

## SPECIFICATIONS OF THE BH CORE CONTROL PANEL/DISPLAY

Characteristics	Specification
Functions	Change of assistance mode. / On and off. / Display of the charge level. / Display of errors.

## SPEED SENSOR SPECIFICATIONS

Characteristics	Specification
Assembly	On the left chainstay. Internal cabling.
Magnet	On the rear brake disc.

# 09 ASSEMBLY AND SPARE PARTS

## DIMENSIONS OF THE STEERING TUBE

ALL MODELS

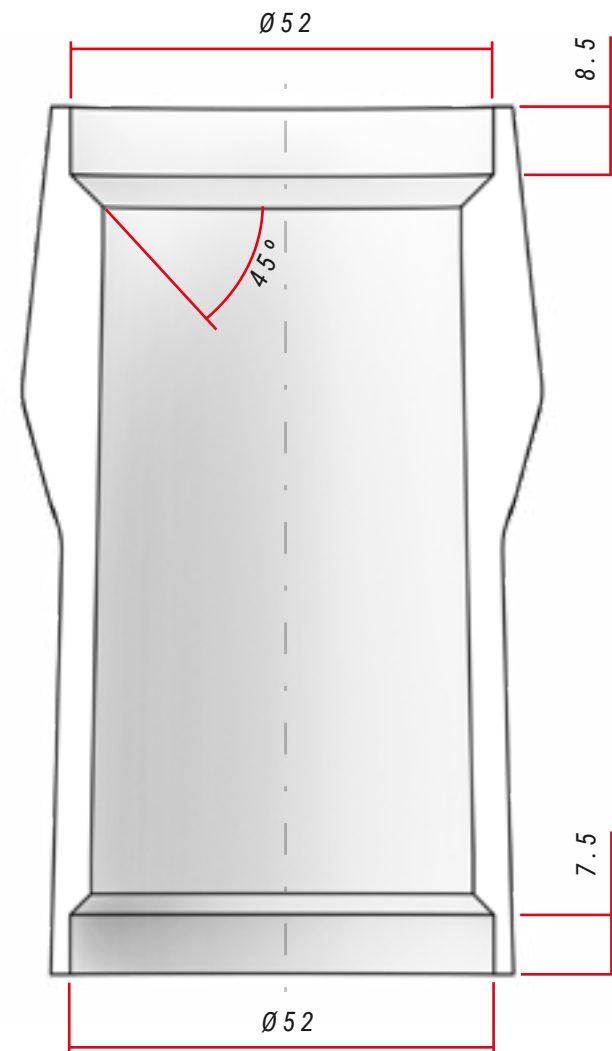

### STEERING SPECIFICATIONS

Type	Contact angle with the compression ring / fork track	Bearing dimensions
Upper	45°	52x40x8
Lower	45°	52x40x8

## HEADSET ASSEMBLY

ALL MODELS

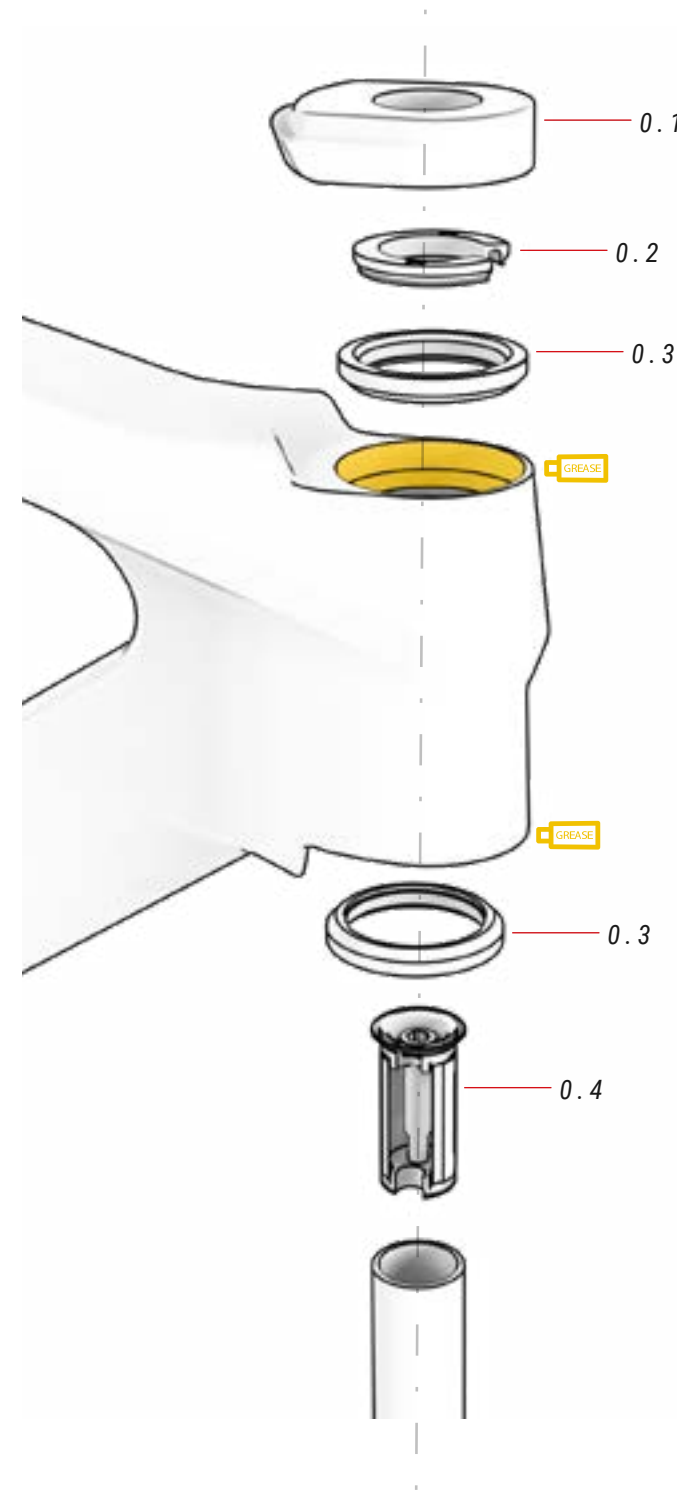

⚠ Carbon forks must never be mounted with a spindle. The spindle may force the fork with a pressure for which it has not been designed. It may break and cause an accident.

Always mount the fork with an expander.

### 00 HEADSET

ref.: 383262000

No.	Item	Quantity
0.1	Steering cover	1
0.2	Compressor	1
0.3	Bearing	1
0.4	Expander	1

# BH AERO ACR STEM

EC185 / EC195

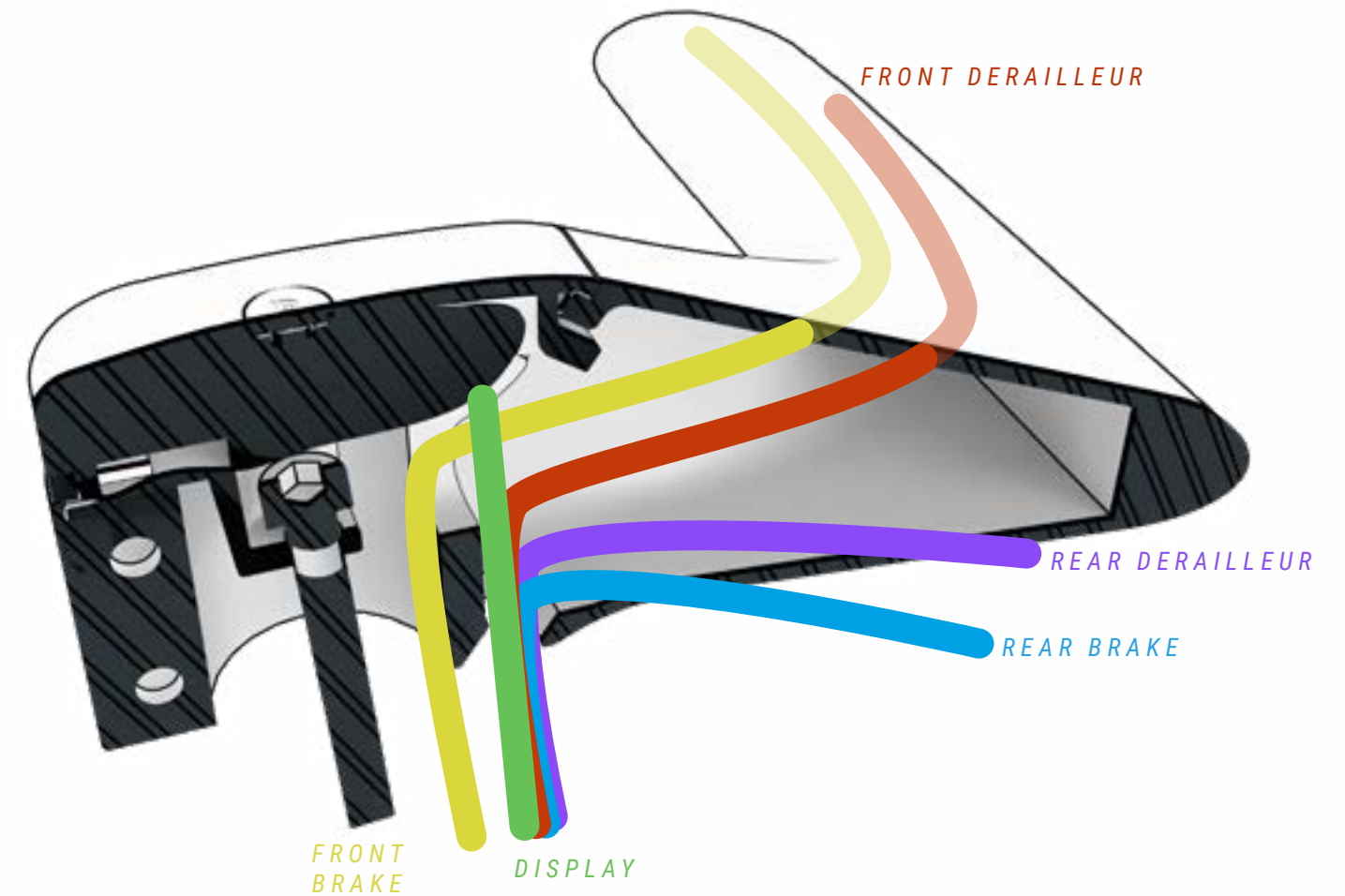
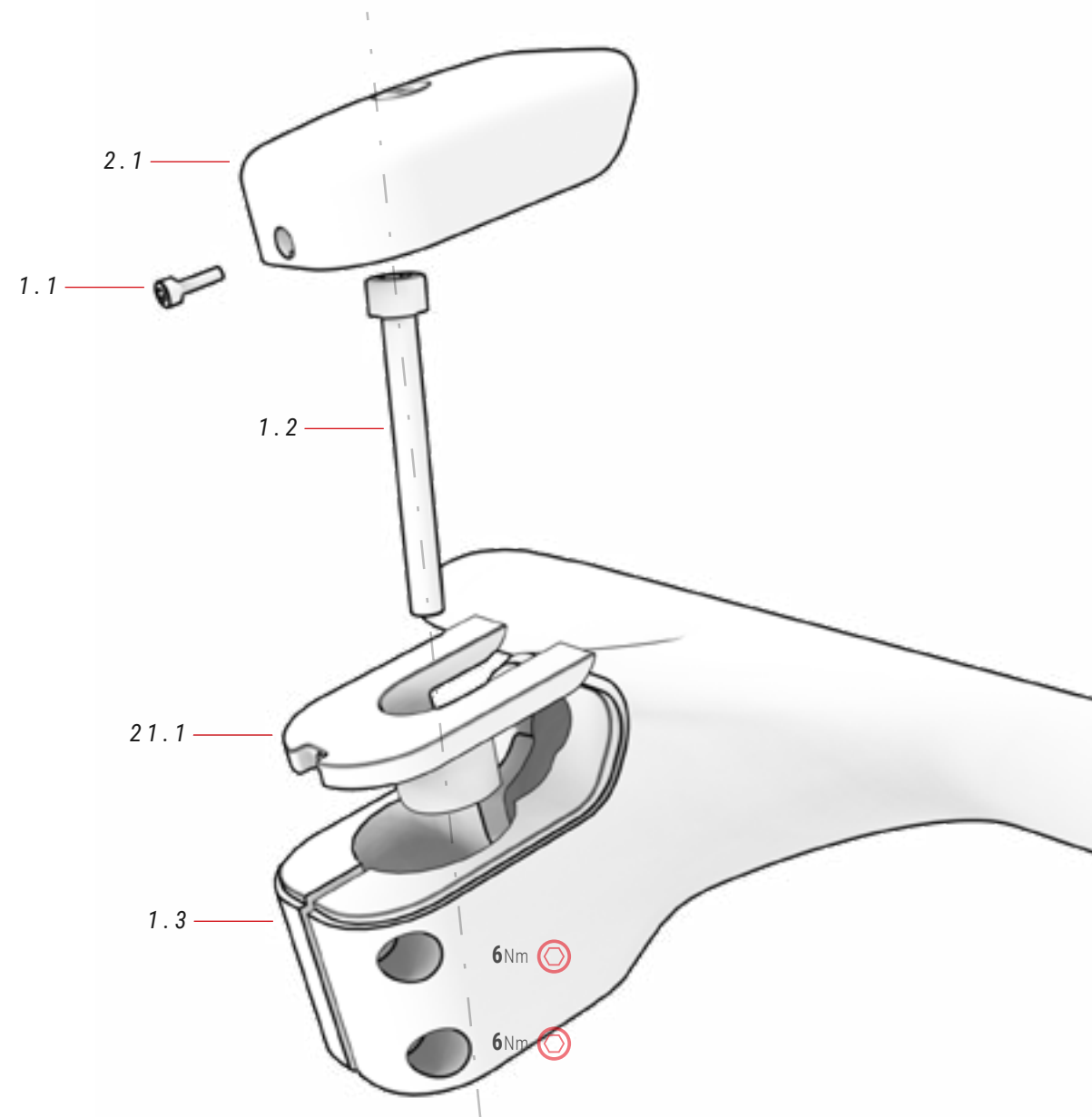

## 02 CORE DISPLAY ref.: 386142300

No.	Item	Quantity
2.1	CORE display	1

## 21 DISPLAY HOLDER ref.: 384632900

No.	Item	Quantity
21.1	Display holder	1

## 01 BH AERO ACR STEM ref.: 391731400

No.	Item	Quantity
1.1	Display bolt	1
1.2	Bolt	1
1.3	Stem	1

# BH LITE AHEAD STEM

EC175

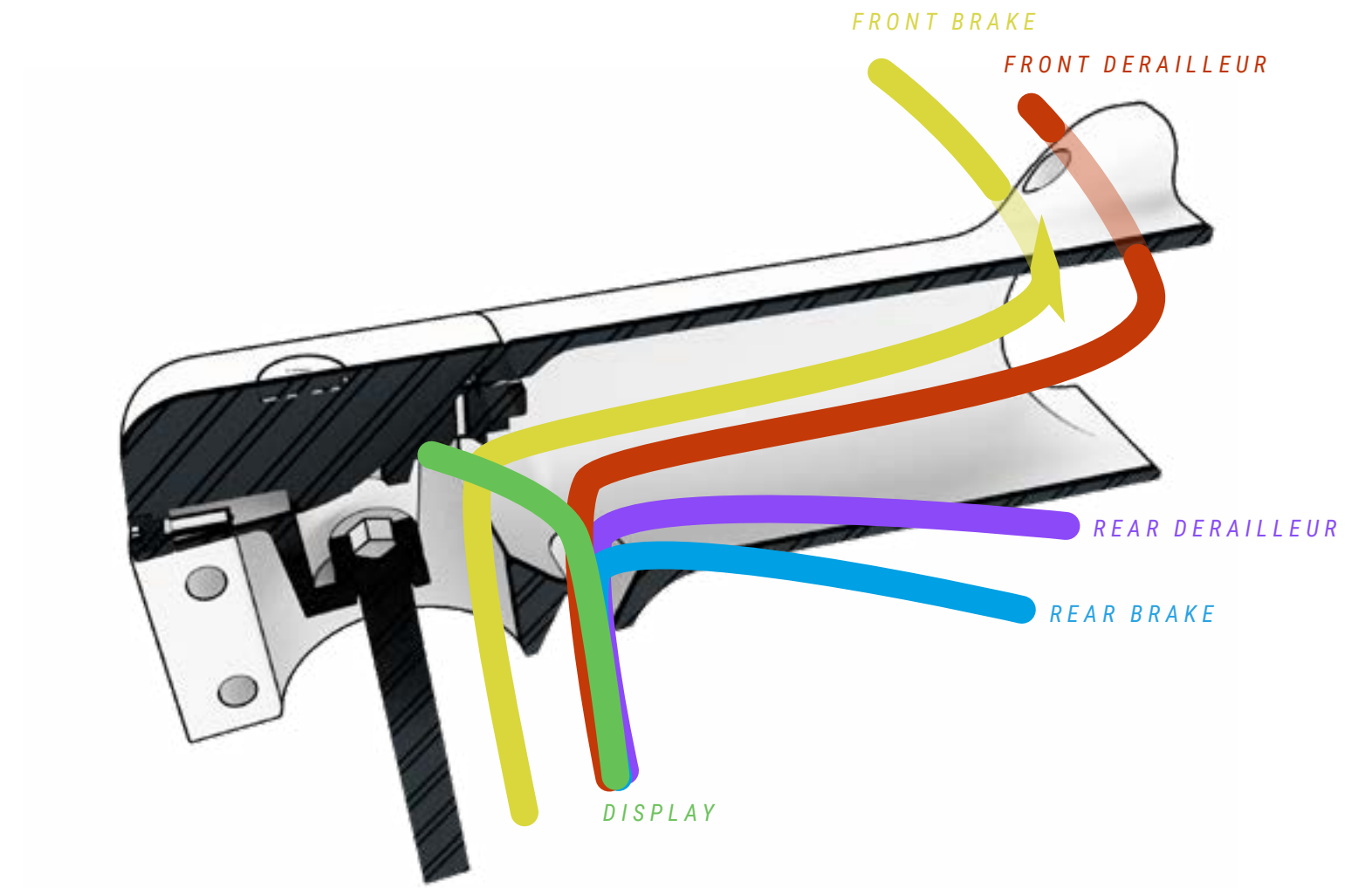
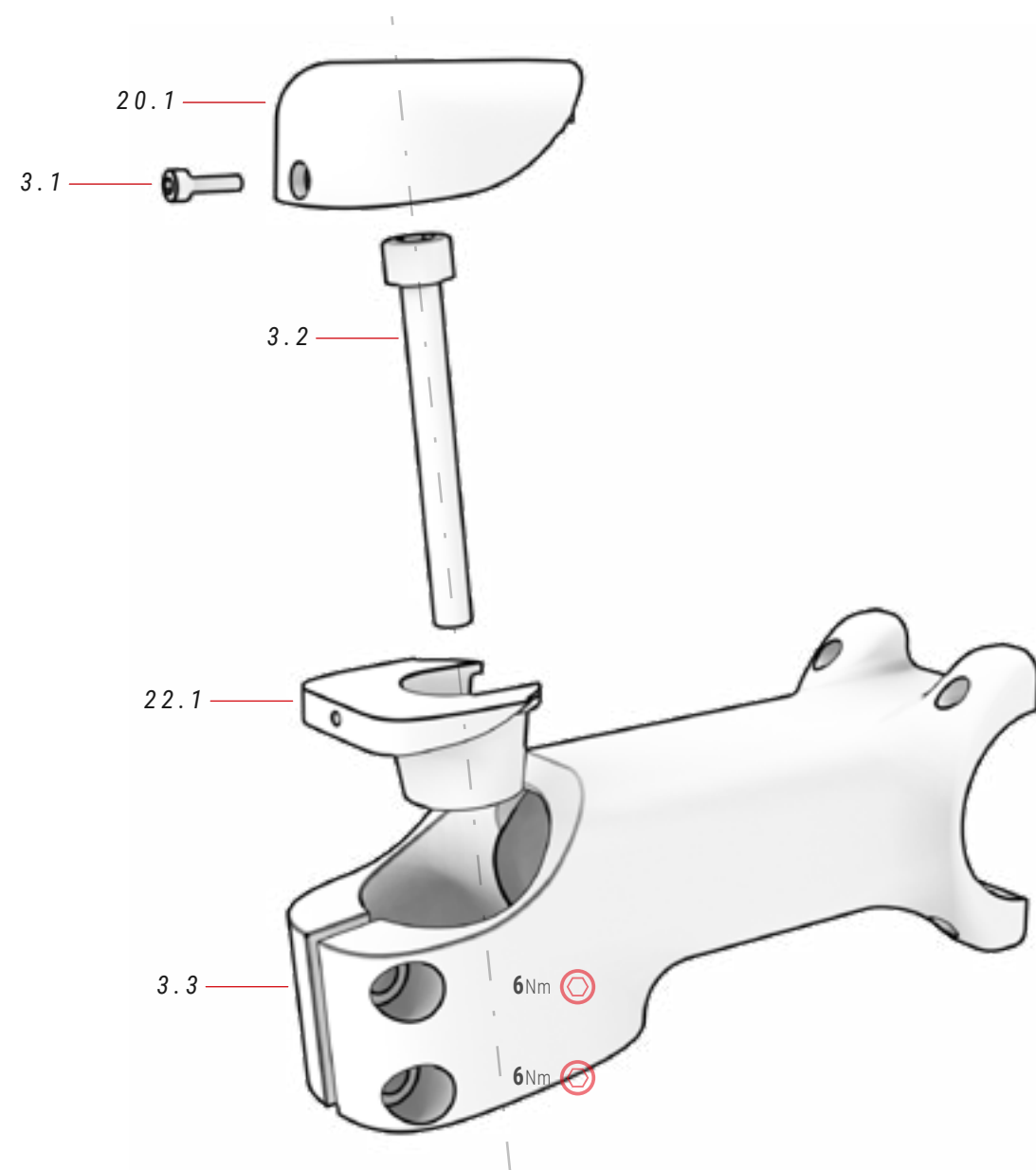

## 20 DISPLAY CORE ref.: 386142100

No.	Item	Quantity
20.1	Display CORE	1

## 22 DISPLAY HOLDER ref.: 384625000

No.	Item	Quantity
22.1	Display holder	1

## 03 FSA ACR STEM

No.	Item	Quantity
3.1	Display bolt	1
3.2	Bolt	1
3.3	Stem	1

## SADDLE SEAT POST ASSEMBLY

ALL MODELS

1. ADD GREASE AND ASSEMBLY PASTE AS SHOWN IN THE PICTURE.

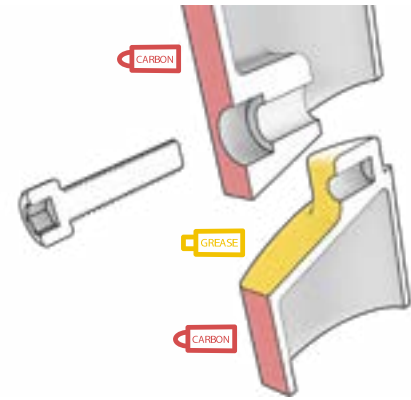

2. ASSEMBLE PARTS 6.1 AND 6.2 OUT OF THE BOX.

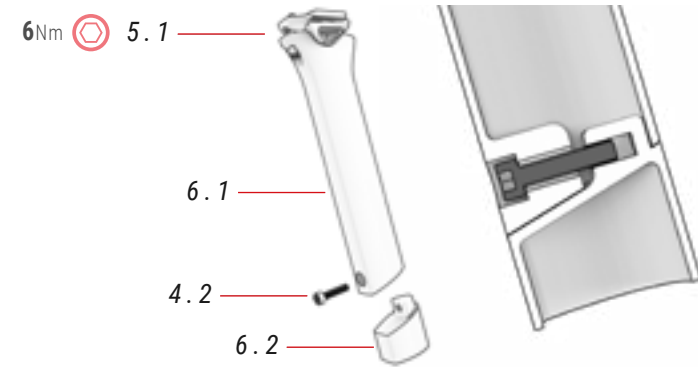

⚠ Bolt 4.2 must be inside the seat post and parts 6.1 and 6.2 aligned.

3. INSERT THE SEAT POST INTO THE FRAME AT THE DESIRED HEIGHT AND TIGHTEN THE BOLT.

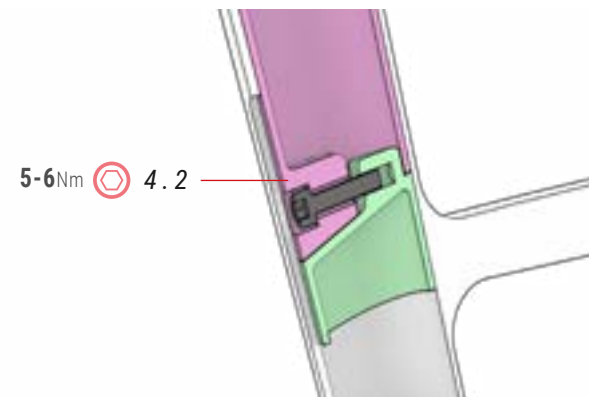

⚠ Always observe the specified maximum and minimum heights to ensure that the integrated seatpost clamping system functions correctly. Damage resulting from incorrect adjustment will not be covered by the warranty and could lead to serious accidents.

4. ADD THE DECORATIVE SNAP-ON COVER.

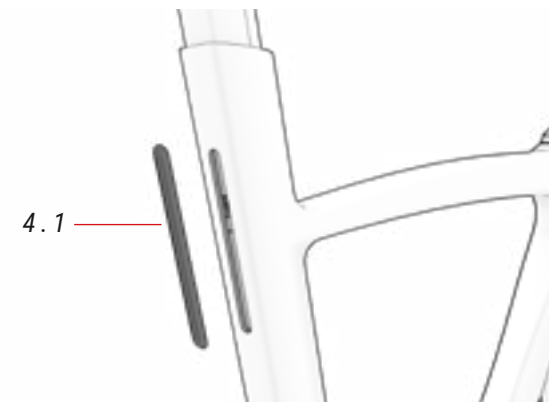

### 06 SEAT POST

ref.: 383254900

No.	Item	Quantity
6.1	Upper seatpost	1
6.2	Lower seatpost	1

### 04 SEAT POST CLAMP COVER

ref.: 391771100

No.	Item	Quantity
4.1	Seat post clamp cover	1
4.2	Seat post bolt M6xP1.0x25 mm	1

## HANGER

ALL MODELS

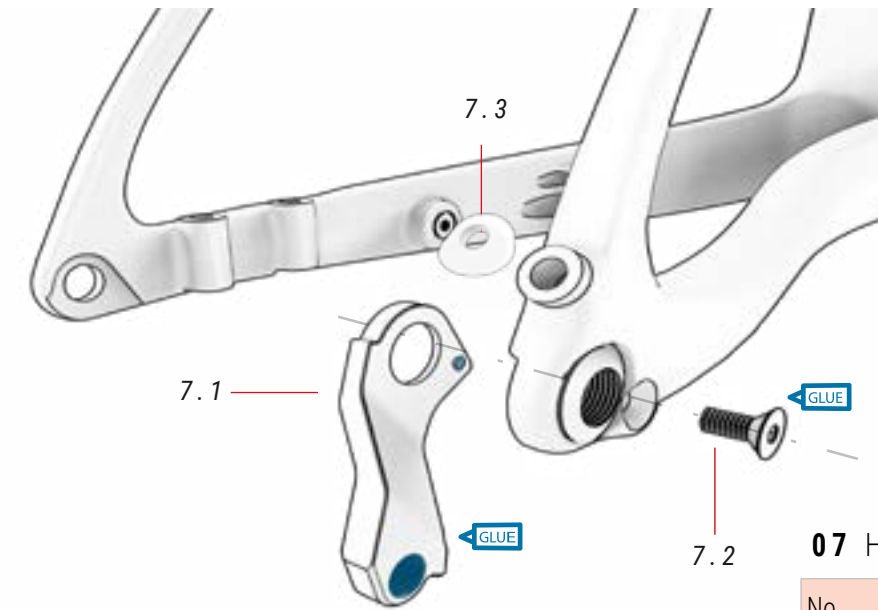

### 07 HANGER

ref.: 391835800

No.	Item	Quantity
7.1	Hanger	1
7.2	Bolt	1
7.3	Gromet	2

## DI2 BATTERY

ALL MODELS



### 05 POST NUT

ref.: 391811300

No.	Item	Quantity
5.1	Nut	1

### 08 DI2 HOLDER

ref.: 391836700

No.	Item	Quantity
8.1	DI2 Holder	1
8.2	Bolt	1
8.3	Screw	2



# FRONT DERAILLEUR BRACKET

ALL MODELS

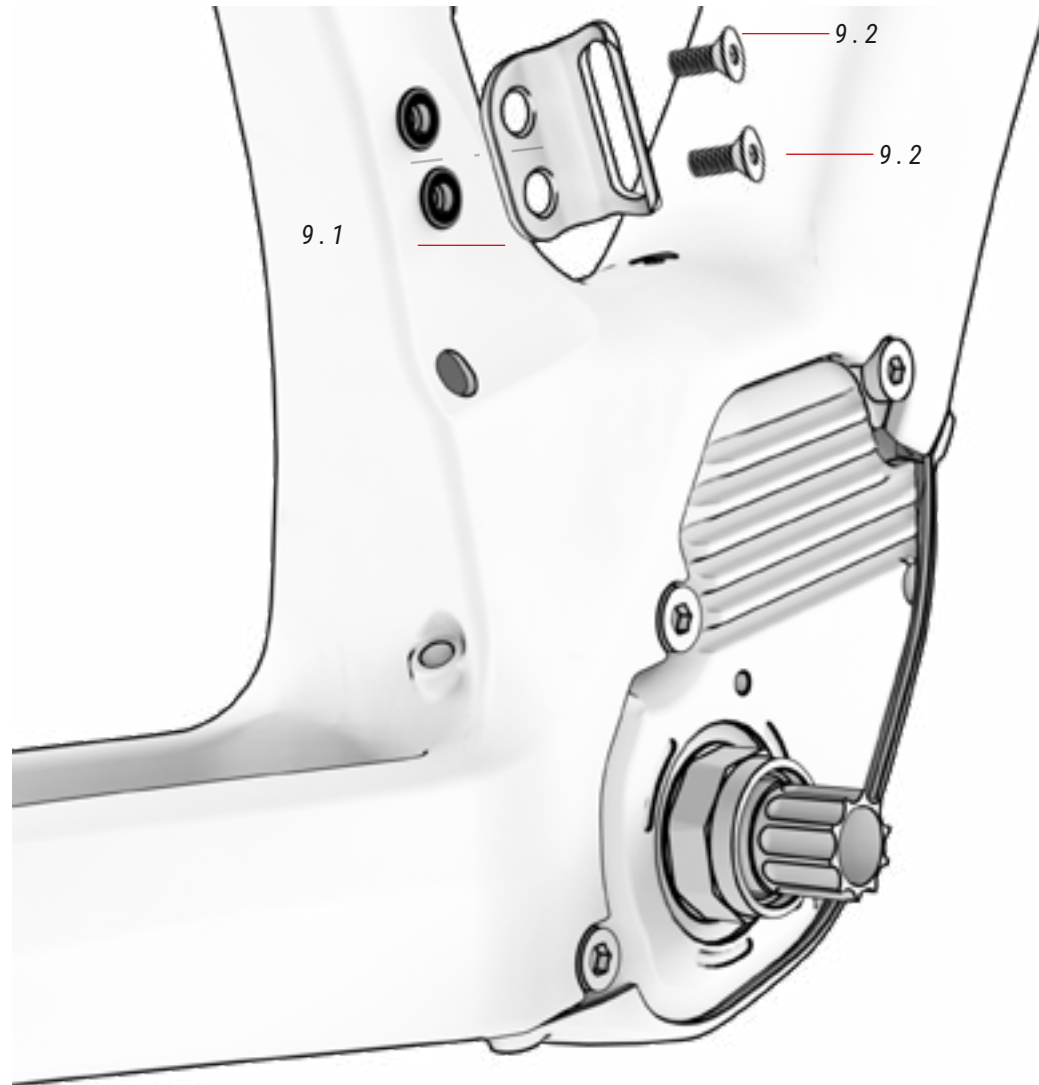

## 09 FRONT DERAILLEUR BRACKET ref.: 391836000

No.	Item	Quantity
9.1	Front derailleur bracket	1
9.2	Screw	2

# MOTOR

ALL MODELS

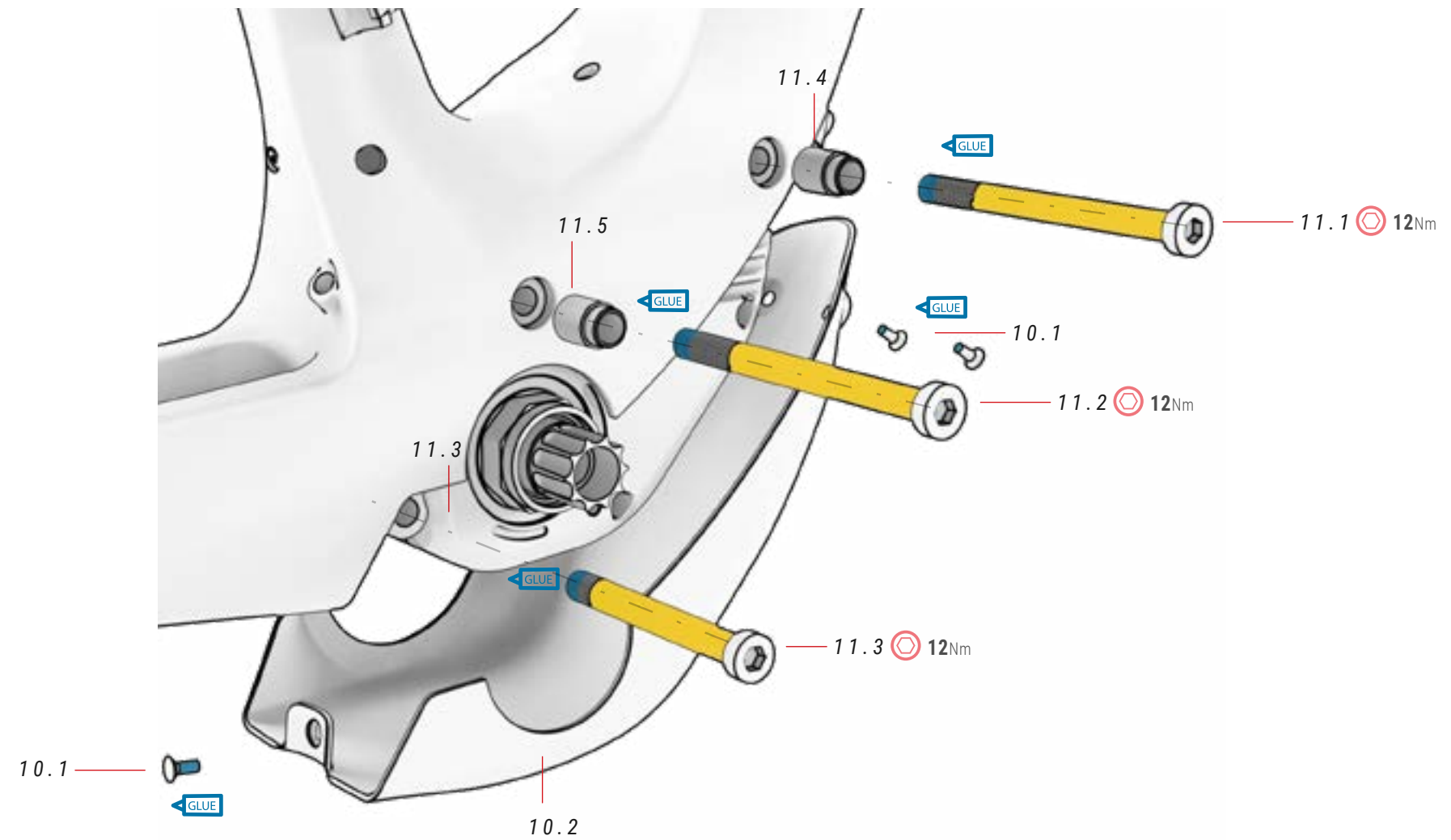

## 10 MOTOR COVER ref.: 391836200

No.	Item	Quantity
10.1	Lower motor cover bolt	3
10.2	Lower motor cover	1

## 11 MOTOR BOLTS ref.: 391836300

No.	Item	Quantity
11.1	Motor bolts	1
11.2	Motor bolt	1
11.3	Motor bolt	1
11.4	Motor bolt guide	1
11.5	Motor bolt guide	1

## CHARGING PORT

ALL MODELS

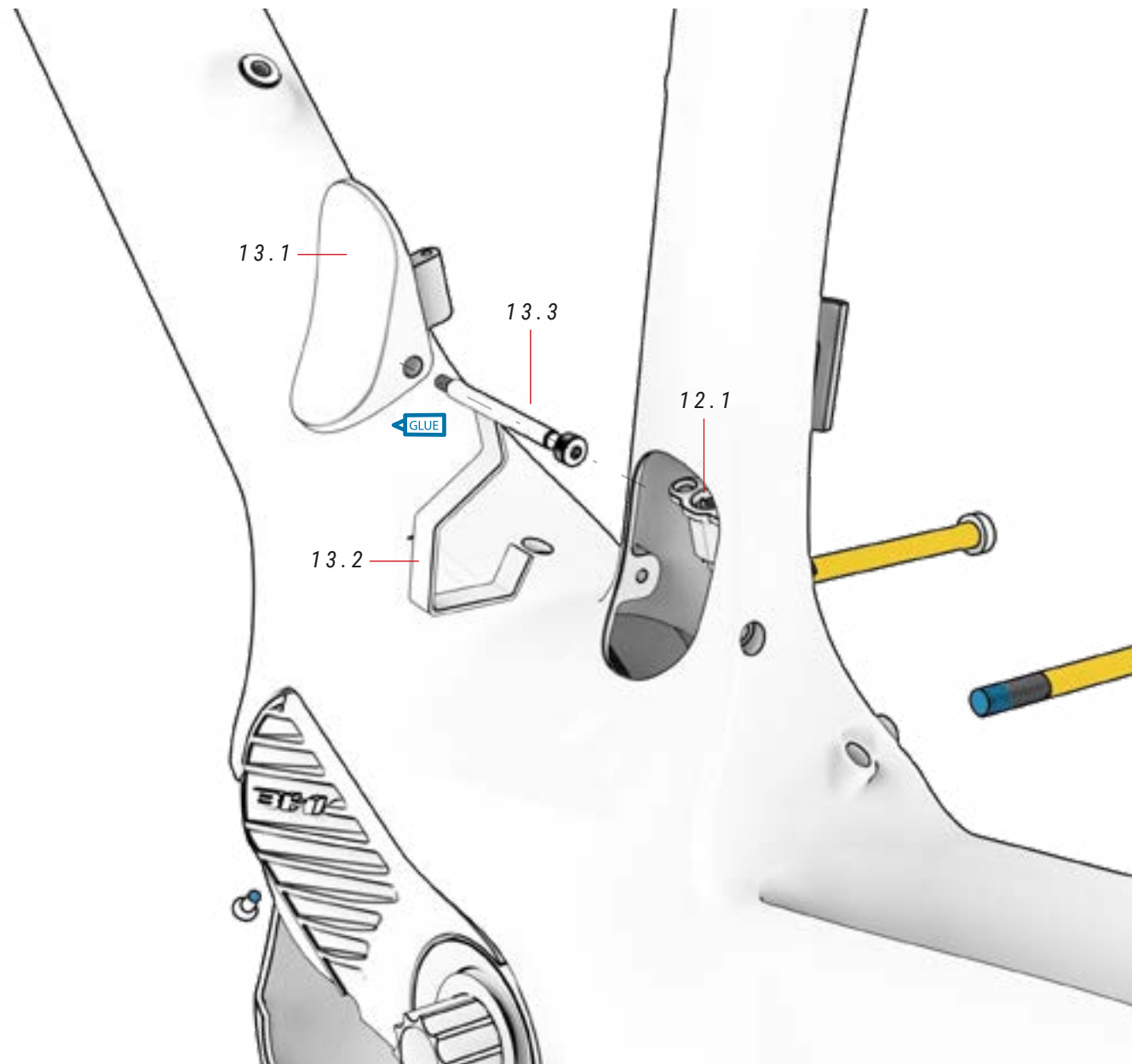

**12 CHARGING PORT** *ref.: 386136200*

No.	Item	Quantity
12.1	Charging port	1

**13 CHARGING PORT COVER** *ref.: 391836400*

No.	Item	Quantity
13.1	Cover	1
13.2	Support	1
13.3	Screw	1

## PLUGS XPRO

ALL MODELS

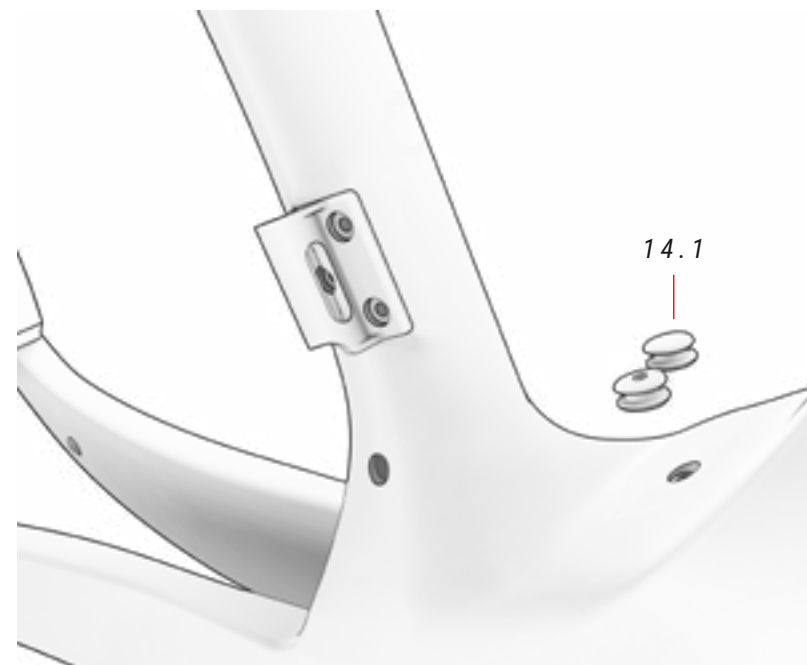

**14 PLUGS XPRO** *ref.: 386221400*

No.	Item	Quantity
14.1	XPro Plugs	2

## SPEED SENSOR

ALL MODELS

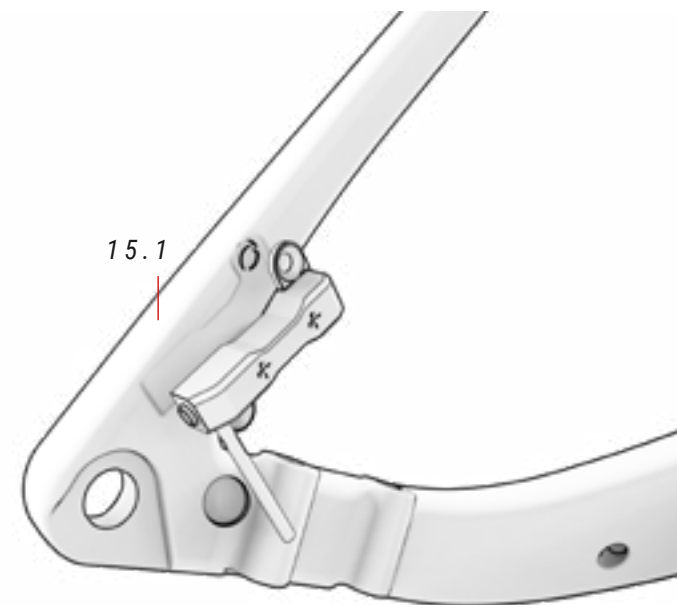

**15 SPEED SENSOR** *ref.: 387463300*

No.	Item	Quantity
15.1	Speed sensor	1

# XPRO BOTTLE HOLDER

ALL MODELS

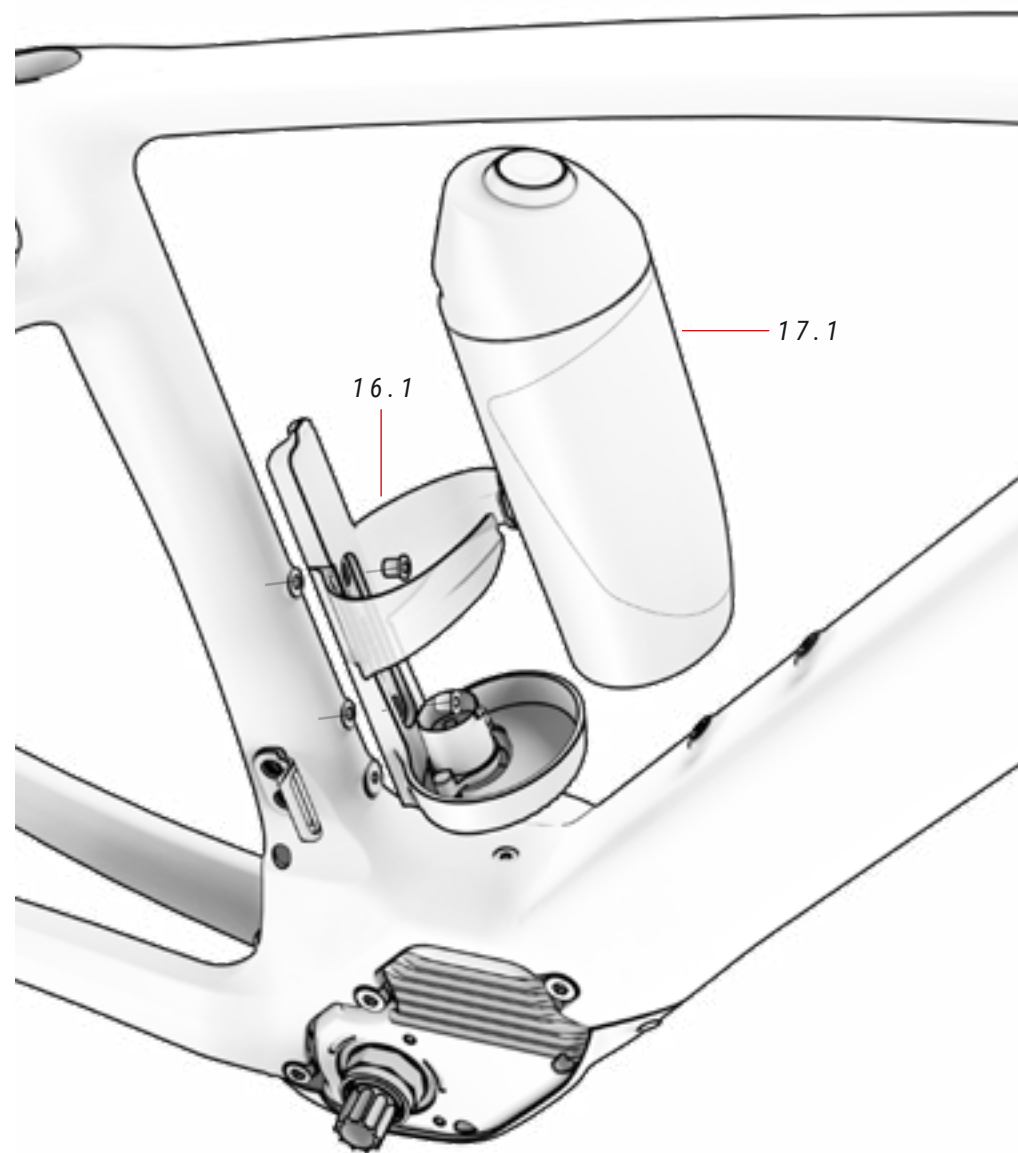

## 16 KIT BOTTLE HOLDER XPRO ref.: 387464000

No.	Item	Quantity
16.1	XPRO bottle holder	1

## 17 BOTTLE XPRO ref.: 387464100

No.	Item	Quantity
17.1	XPRO bottle	1

BOTTLE HOLDER XPRO  
ASSEMBLY VIDEO

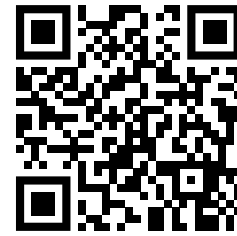

0

<https://youtu.be/UrMfZvXCPnA>

⚡ Refer to the section "Wiring diagrams of the electrical system" in this manual for information about the proper fitting and installation of all electrical components.

⚠ Excessively long bolts on the down tube may cause damage to the battery that is not covered by the warranty. Never force the bolts.

⚠ Not compatible with XPRO+.

# BATTERY HOLDER

ALL MODELS

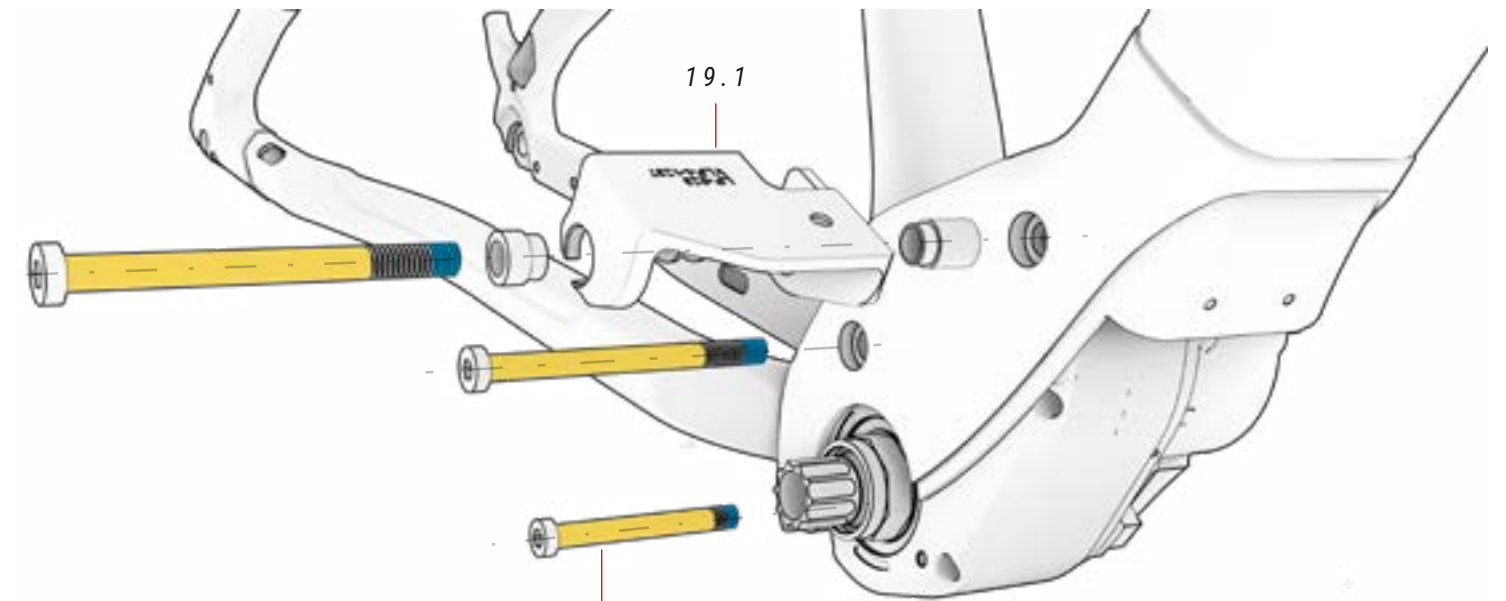

## 19 BATTERY HOLDER ref.: 387462900

No.	Item	Quantity
19.1	Battery holder	1

## 18 XPRO COVER ref.: 386139400

No.	Item	Quantity
18.1	Cover XPro	1

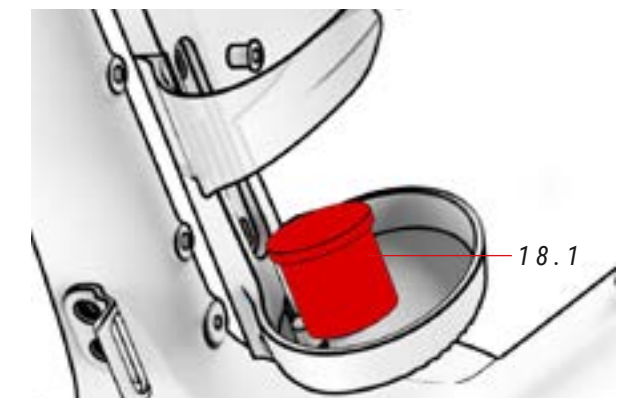

## CABLING OF THE MECHANICAL PARTS

The images below show the routing configuration for the mechanical component cables. The cables will remain protected inside the frame triangle until they come out through the motor cover for ease of maintenance.

ALL MODELS

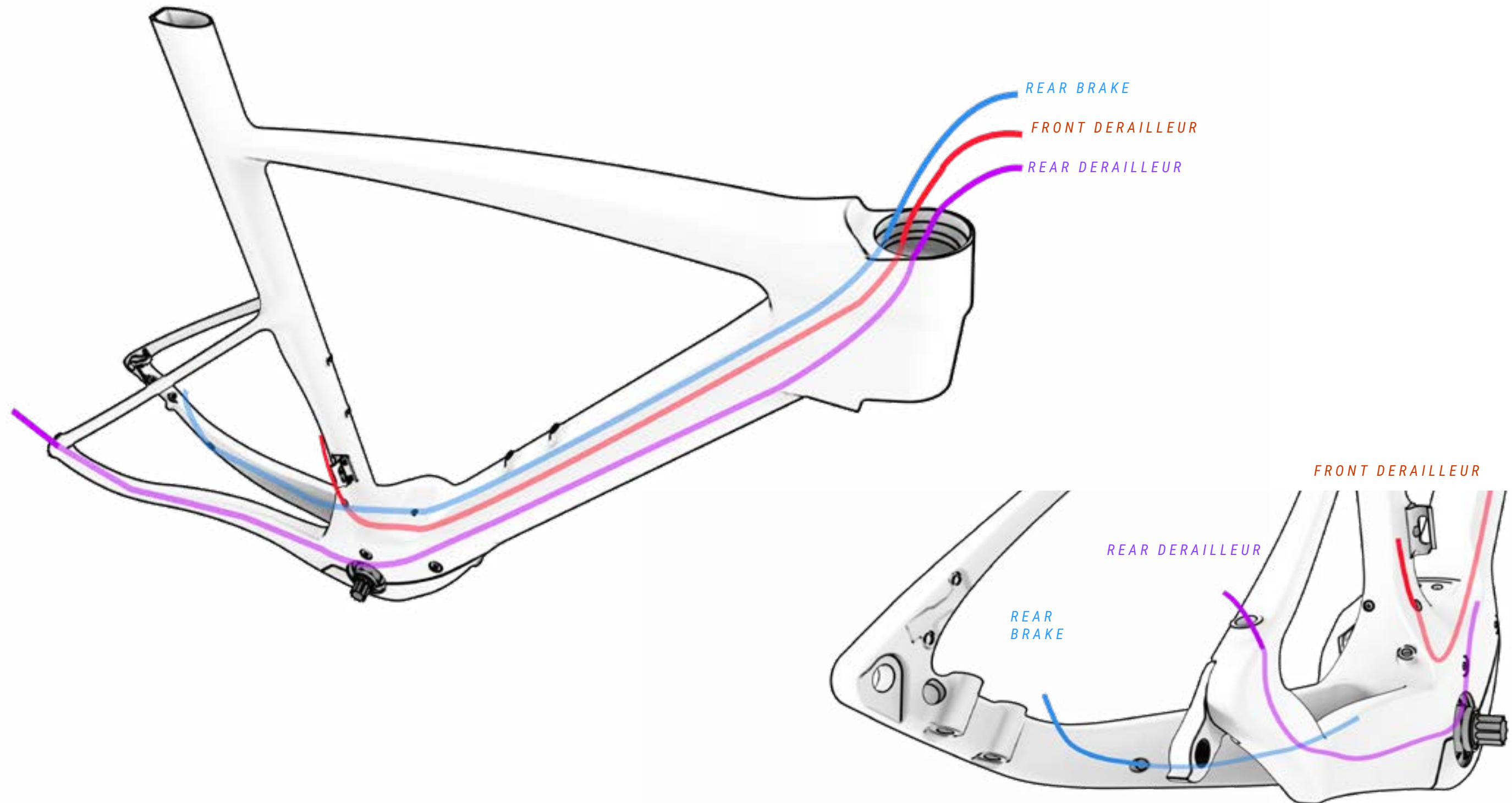

# CABLING OF THE ELECTRICAL SYSTEM'S PARTS

ALL MODELS

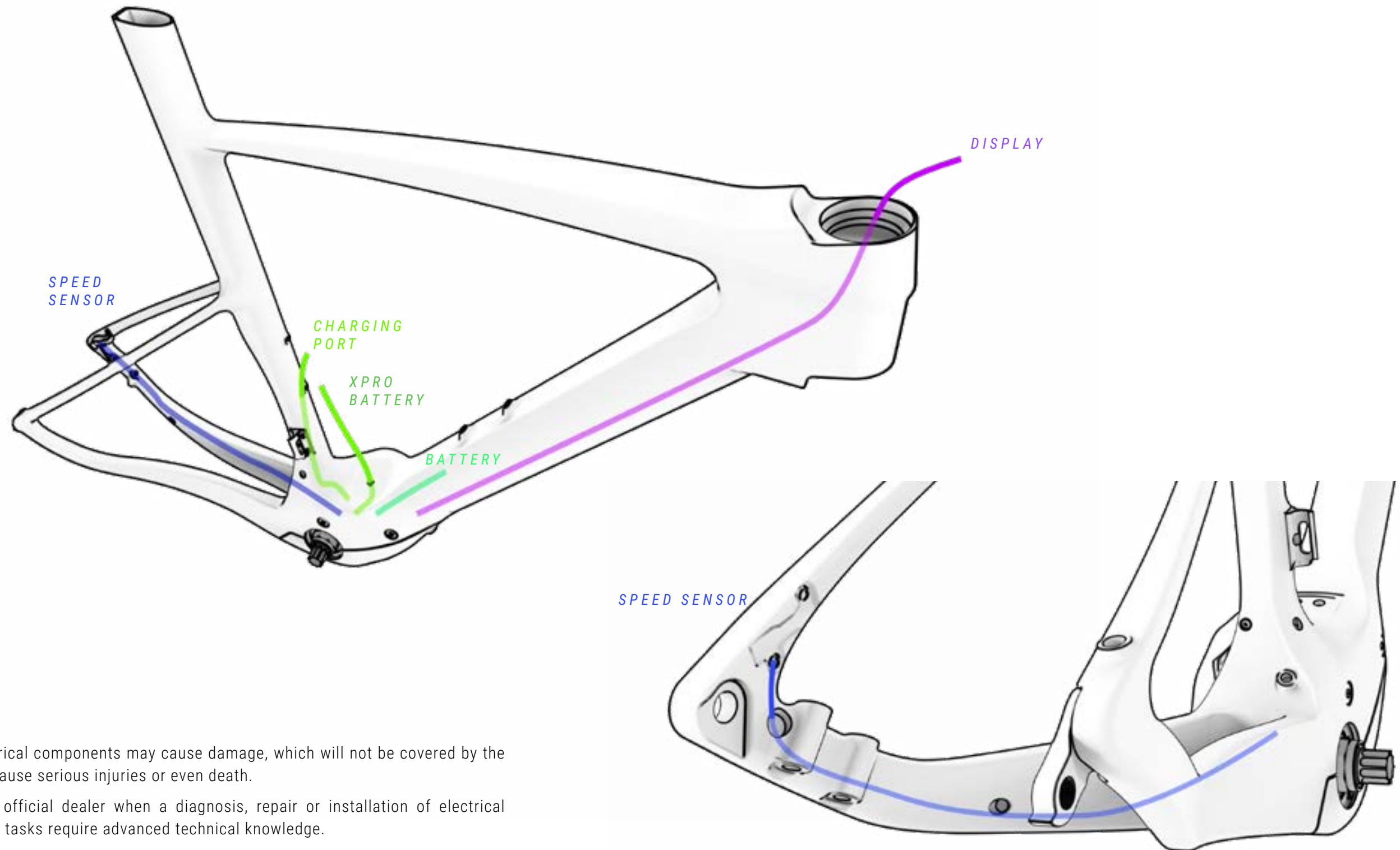

⚠ Incorrect handling of the electrical components may cause damage, which will not be covered by the warranty. Such damage may cause serious injuries or even death.

BH recommends going to an official dealer when a diagnosis, repair or installation of electrical components is required. These tasks require advanced technical knowledge.

# WIRING DIAGRAM OF THE ELECTRICAL SYSTEM'S PARTS

ALL MODELS

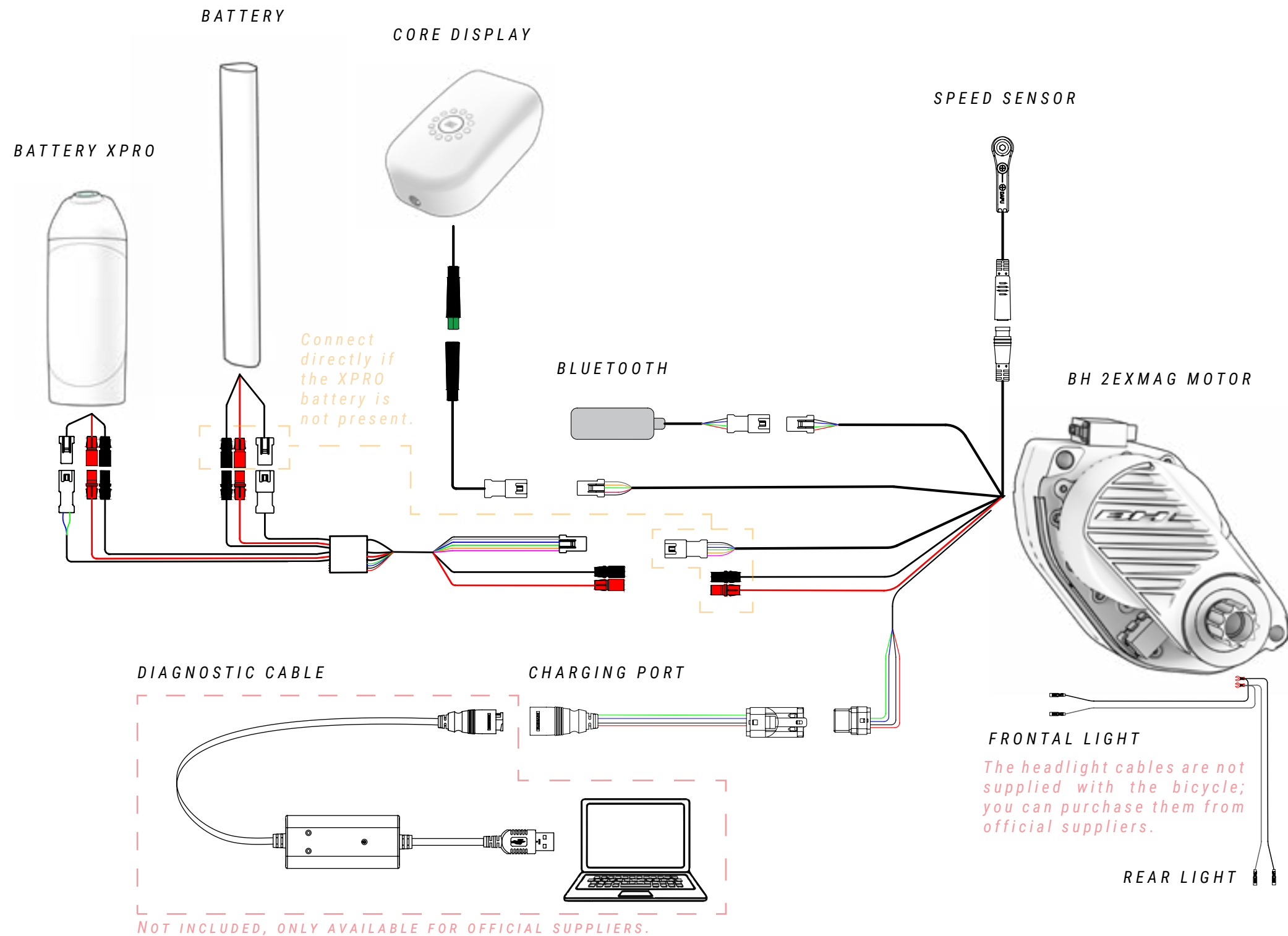

⚠ Incorrect handling of the electrical components may cause damage, which will not be covered by the warranty. Such damage may cause serious injuries or even death.

BH recommends going to an official dealer when a diagnosis, repair or installation of electrical components is required. These tasks require advanced technical knowledge.



⚠ When electrical connections come into contact with damp spots or are clogged due to external contamination, a chemical reaction occurs, causing a build-up of lead sulphate crystals in the connections. In other words, the copper on the contacts will rust, resulting in conductivity problems.

The warranty does not cover damage caused by incorrect maintenance of the bicycle's connections. To prevent rust, simply clean the connections (male and female) at regular intervals, using dielectric deoxidisers like the one shown in the image above.

# 10 DECLARATION OF CONFORMITY

**EU Declaration of Conformity** 

**The manufacturer:** BH BIKES EUROPE, SL  
c/ Perretagana 10,  
01015 Vitoria, Spain

**Hereby declares that the following products:**

**Product description:**  Cycles –Electrically power assisted cycles –EPAC Bicycles

**Models designation:**

iLYNX+ ENDURO 9.9, iLYNX+ ENDURO 9.8, iLYNX+ ENDURO 9.7, iLYNX+ SL ENDURO 9.6, iLYNX+ SL ENDURO 9.5, iLYNX+ SL ENDURO 9.4, iLYNX+ TRAIL 8.9, iLYNX+ TRAIL 8.8, iLYNX+ TRAIL 8.7, iLYNX+ SL TRAIL 0.0, iLYNX+ SL TRAIL 8.6, iLYNX+ SL TRAIL 8.5, iLYNX+ SL TRAIL 8.4.

ATOMe LYNX PRO 8.2, ATOMe LYNX 8.0.

iLYNX TRAIL CARBON 8.9, iLYNX TRAIL CARBON 8.8, iLYNX TRAIL CARBON 8.7.

iLYNX TRAIL 8.2, iLYNX TRAIL 8.1, iLYNX TRAIL 8.0.

iLYNX RACE 7.9, iLYNX RACE 7.8, iLYNX RACE 7.7.

iAEROLIGHT 1.9, iAEROLIGHT 1.8, iAEROLIGHT 1.7.

iRS1 CARBON 1.6, iRS1 CARBON 1.5, iRS1 CARBON 1.4, iRS1 1.2.

iGRAVELX CARBON 2.9, iGRAVELX CARBON 2.8, iGRAVELX CARBON 2.7, iGRAVELX 2.4, iGRAVELX 2.2.

ATOMe PRO, ATOMe JET PRO, ATOMe CROSS PRO, ATOMe SUV PRO-SE, ATOMe SUV PRO-S, ATOMe SUV PRO, ATOMe DIAMOND WAVE PRO, ATOMe CITY WAVE PRO.

CORE PRO, CORE 29, CORE JET PRO, CORE CROSS PRO, CORE JET, CORE CROSS, CORE CITY WAVE, CORE STREET.

ATOM LYNX PRO 8.2, ATOM LYNX 8.1, ATOM LYNX 8.0, ATOM PRO, ATOM 29, ATOM JET PRO, ATOM CROSS PRO, ATOM JET, ATOM CROSS, ATOM SUV PRO, ATOM DIAMOND WAVE PRO, ATOM CITY WAVE PRO, ATOM CITY WAVE, ATOM CITY, ATOM STREET.

ATOMX LYNX 9.9, ATOMX LYNX 9.8, ATOMX LYNX 9.7, ATOMX LYNX 8.7.

ATOMX LYNX 9.2, ATOMX LYNX 9.0, ATOMX LYNX 8.4, ATOMX LYNX 8.2, ATOMX CROSS

**Year of manufacture:** 2024 and 2025

Comply with all of the relevant requirements of the Machinery Directive (2006/42/EC).  
Comply with Low Voltage Directive (LVD) 2014/35/EU  
Comply with all of the relevant requirements of RD 339/2014, de 9 de Mayo.

Furthermore, the machine complies with all of the requirements of the Electromagnetic Compatibility Directive 2014/30/EU.

The production control is assured by our Quality Management System, which fulfills the requirements of the standard ISO 9001

The following harmonized standards have been applied:  
DIN EN 15194 Cycles – Electrically power assisted cycles – EPAC bicycles;  
DIN ISO 4210-1/2/3/4/5/6/7/8/9 Safety requirements for bicycles

**Technical documentation filed at:**  
BH BIKES EUROPE, SL  
c/ Perretagana 10,  
01015 Vitoria, Spain

Prepared and reviewed by the BH Quality Department (Headquarters)

Rev.18 03/07/2024 Page 1 of 1

# 11 HELP AND ADDITIONAL RESOURCES

BH offers different channels to resolve your queries. In addition, you can join our global cyclist community on our social media.

## TECHNICAL RESOURCES

You can find all of the resources you need to fine-tune your bicycle on the BH Bikes website. Click on the link below to access the user manuals, apps, warranties, display update files and videos that explain different operations:

<https://www.bhbikes.com/manuals>

You can also check out our step-by-step tutorials to learn how to maintain and fine-tune your bicycle on our specialised Youtube channel:

<https://www.youtube.com/user/ServicioTecnicoBH>

## CONTACT US

Our authorised dealers have the necessary knowledge and resources to help you with anything you need in relation to your bicycle. Don't hesitate to contact your nearest store. You can find it by clicking on the link below:

[https://www.bhbikes.com/es\\_ES/tiendas/buscador-de-tiendas](https://www.bhbikes.com/es_ES/tiendas/buscador-de-tiendas)

To contact us directly:

Tel.: + 34 945 13 52 02

[info@bhbikes.com](mailto:info@bhbikes.com)

P.I. Jundiz- Perretagana 10, 01015 Vitoria, Alava (Spain)

## SOCIAL MEDIA

Join our global cyclist community. Discover the BH experiences of other cyclists and share yours.





[www.bhbikes.com](http://www.bhbikes.com)

